



**Minipack-torre S.p.A.**  
Via Provinciale, 54 - 24044 Dalmine (BG) - Italy  
Tel. (035) 563525 - Fax (035) 564945  
E-mail: [info@minipack-torre.it](mailto:info@minipack-torre.it)  
<http://www.minipack-torre.it>



# **minipack FM76N**

## **Catalogo ricambi**

( Valido dalla matricola nr. 7221 del 03.1990 fino al nr. 9700 del 10.1993 )

## **Spare parts catalogue**

( Valid from serial number 7221 dated 03.1990 at to 9700 dated 10.1993 )

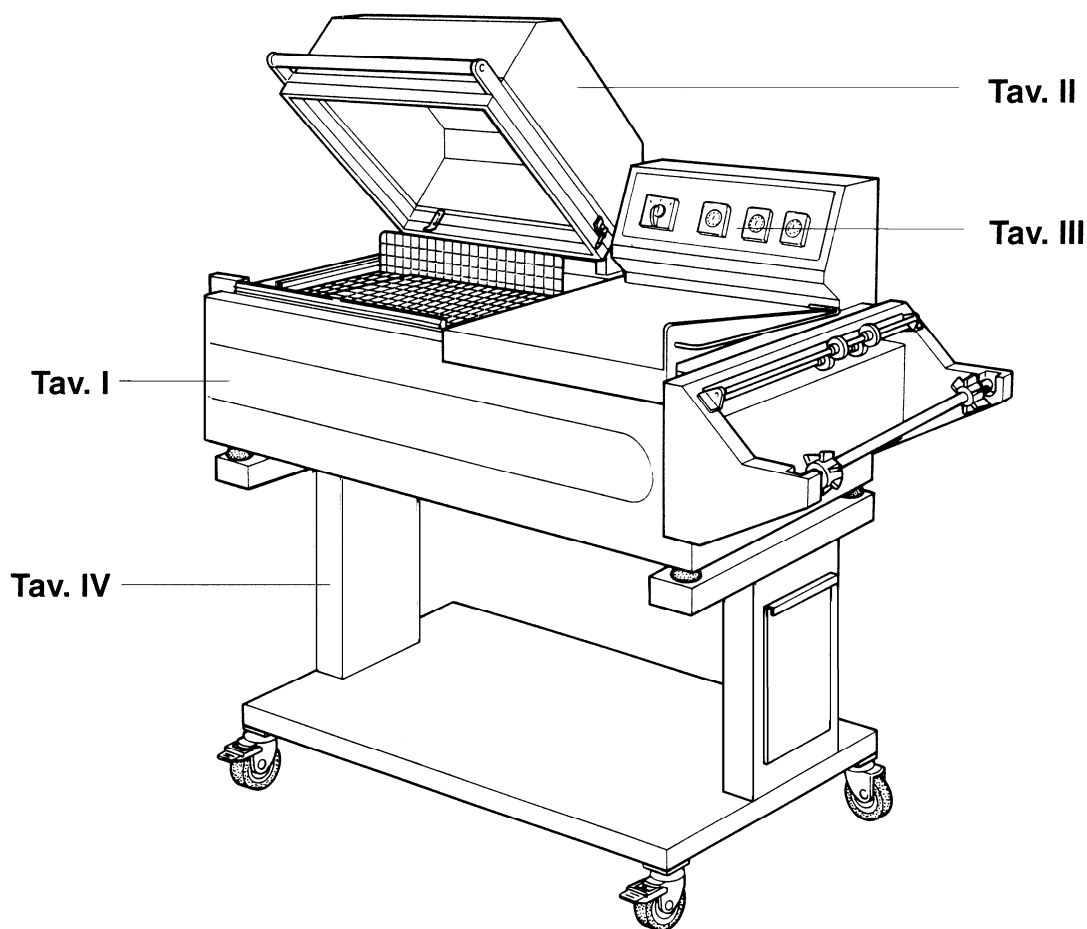

CONSULTARE ATTENTAMENTE QUESTO CATALOGO PRIMA DI ORDINARE PEZZI DI RICAMBIO  
CAREFULLY READ THIS CATALOGUE BEFORE ORDERING SPARE PART

# УПАКОВОЧНОЕ ОБОРУДОВАНИЕ



ПРОИЗВОДСТВО И ПОСТАВКА  
СЕРВИСНЫЙ РЕМОНТ  
ЗАПАСНЫЕ ЧАСТИ  
РАСХОДНЫЕ МАТЕРИАЛЫ

Диагностика, ремонт, сервисное обслуживание.

Запасные части и расходный материал: резина, тефлоновая лента, термонож (лезвие), гель для смазки.

Плѐнка термоусадочная полиолефиновая.

Система «Trade-In» – замена Вашего оборудования на новое и более производительное.



*На фото: запайщик Magnetic FL900 + туннель Magnetic T100*

ООО «АРДсистемы»

(495) 231-21-00

(812) 363-20-22

info@ardsystems.ru

[www.filmtrade.ru](http://www.filmtrade.ru)

[www.ardsystems.ru](http://www.ardsystems.ru)

## **INDICE / INDEX**

<i>ESPLOSO MACCHINA TAVOLA I / SCHEME I MACHINE DETAIL DRAWING</i>	<i>pag./page 2</i>
<i>ESPLOSO MACCHINA TAVOLA II / SCHEME II MACHINE DETAIL DRAWING</i>	<i>pag./page 3</i>
<i>ESPLOSO MACCHINA TAVOLA II Bis / SCHEME II Bis MACHINE DETAIL DRAWING</i>	<i>pag./page 4</i>
<i>ESPLOSO MACCHINA TAVOLA III / SCHEME III MACHINE DETAIL DRAWING</i>	<i>pag./page 5</i>
<i>ESPLOSO MACCHINA TAVOLA IV / SCHEME IV MACHINE DETAIL DRAWING</i>	<i>pag./page 6</i>
<i>ESPLOSO MACCHINA TAVOLA IV Bis / SCHEME IV Bis MACHINE DETAIL DRAWING</i>	<i>pag./page 7</i>
<i>SCHEMA ELETTRICO / WIRING DIAGRAM</i>	<i>pag./page 8</i>

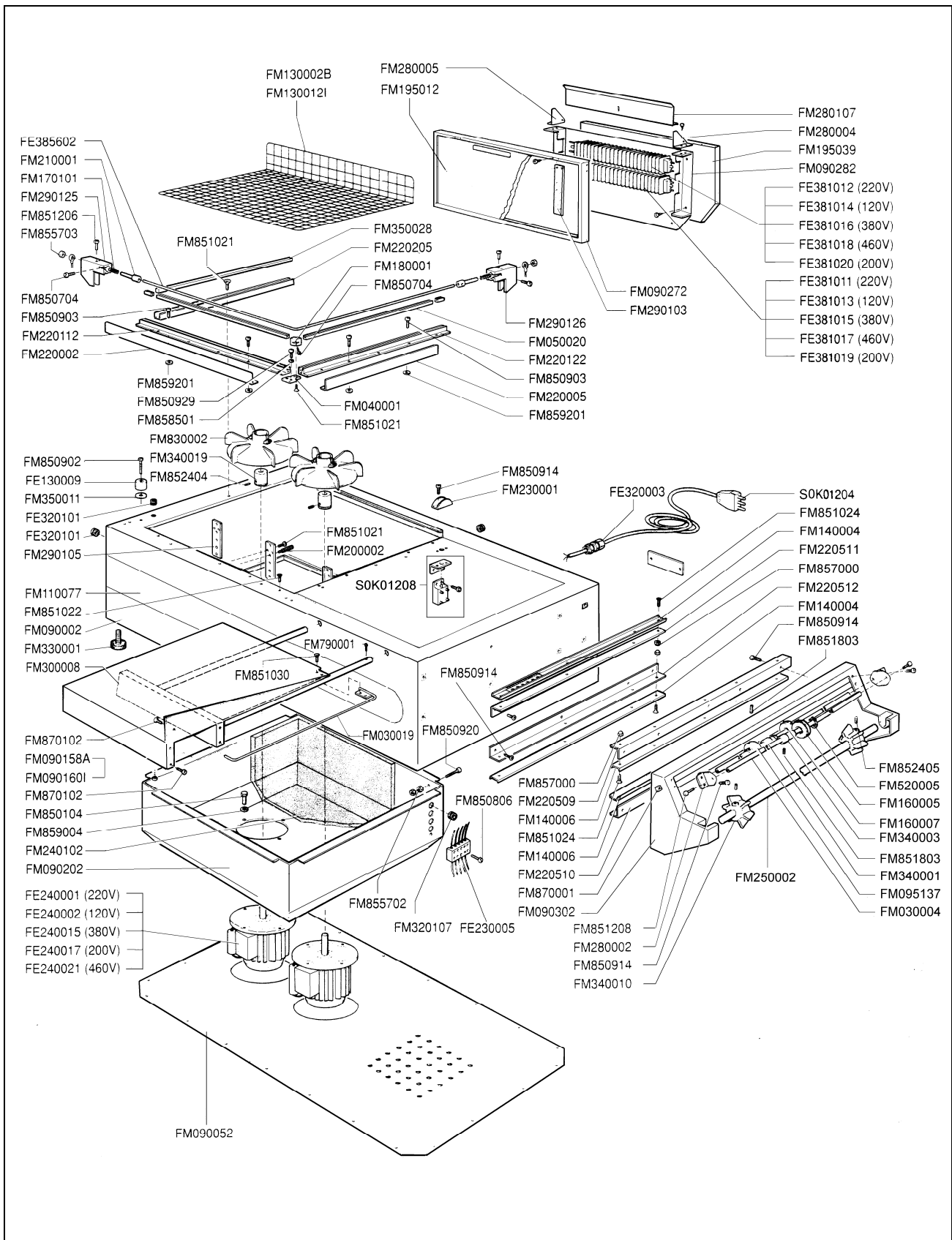

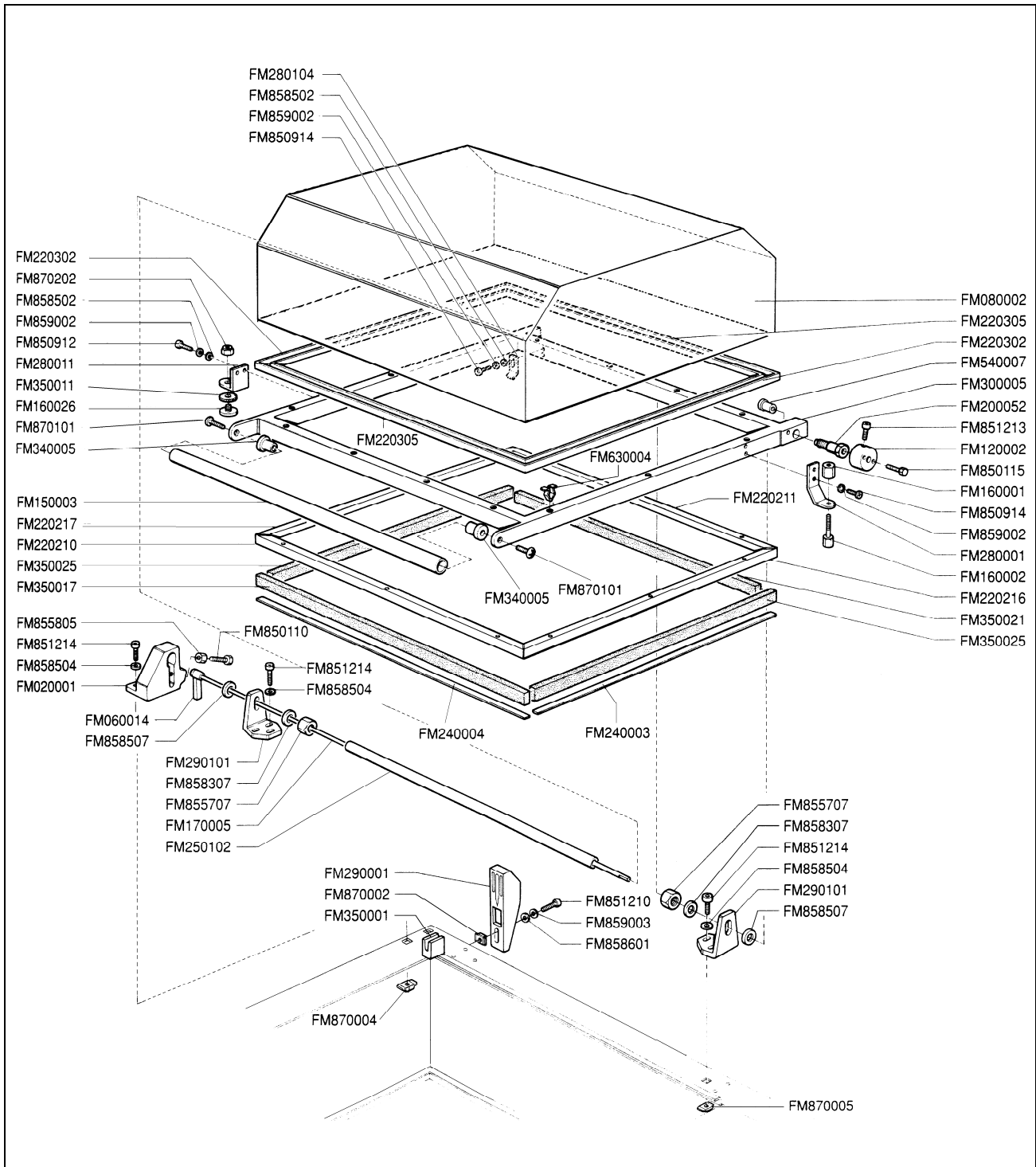

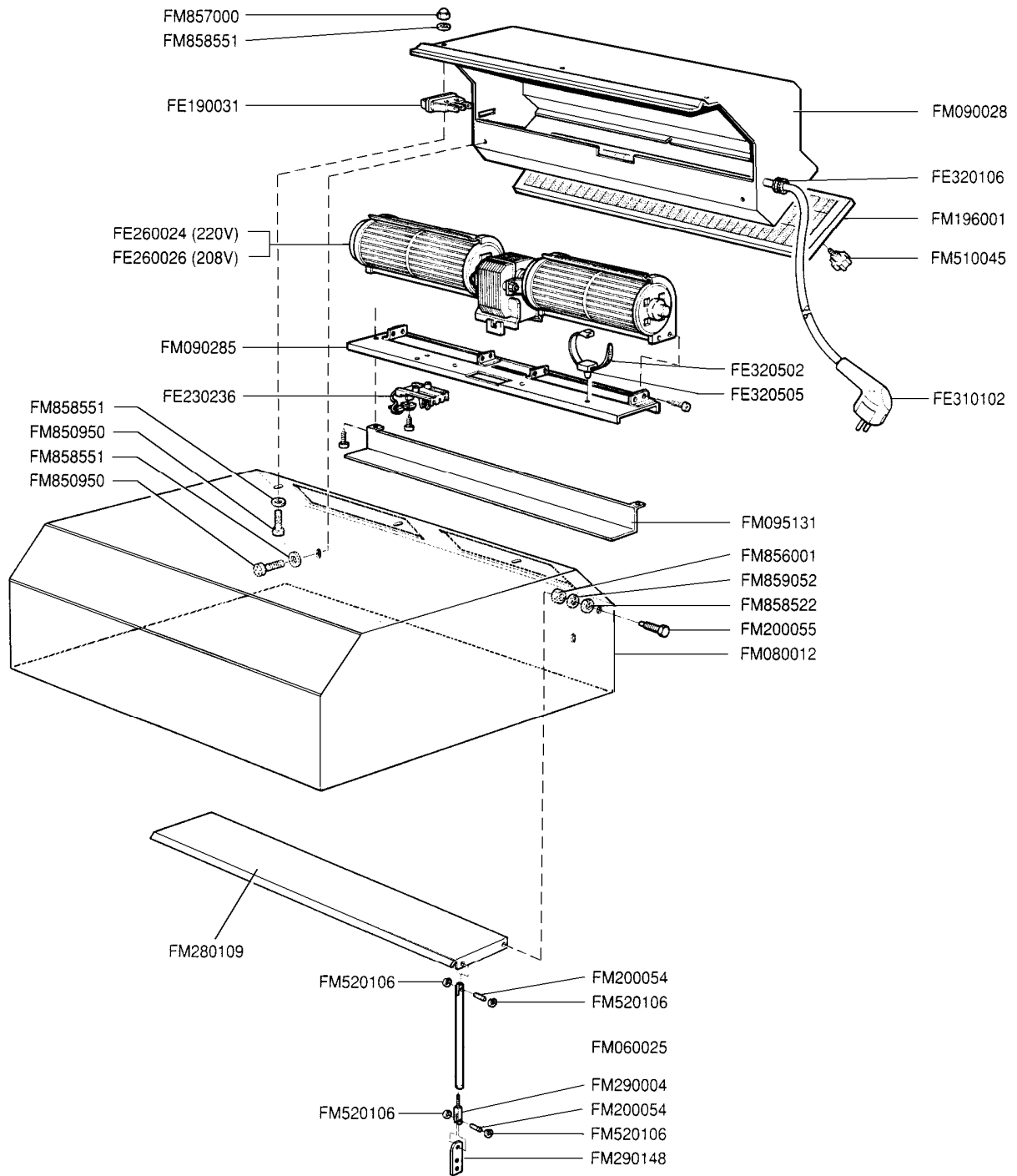

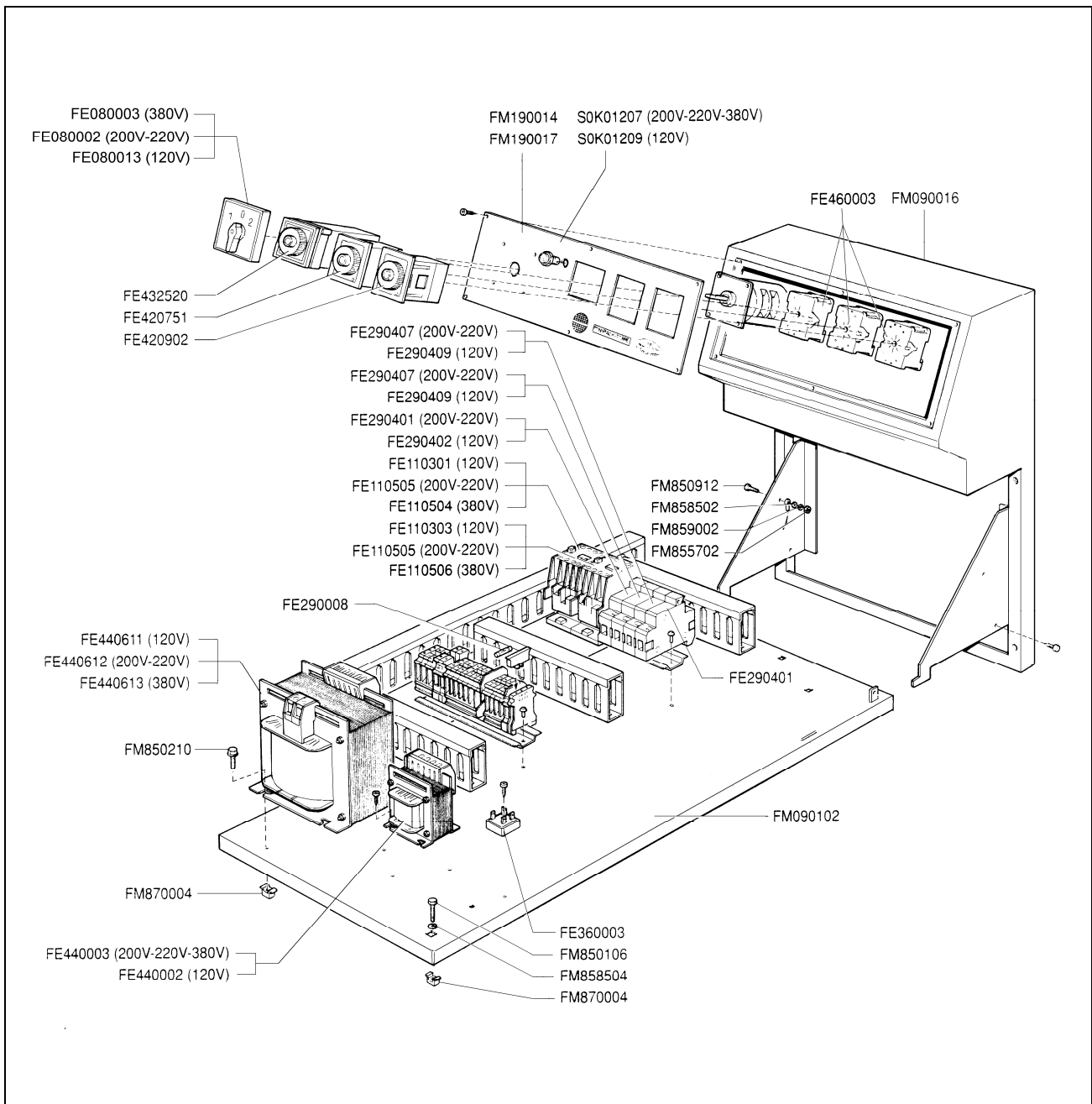

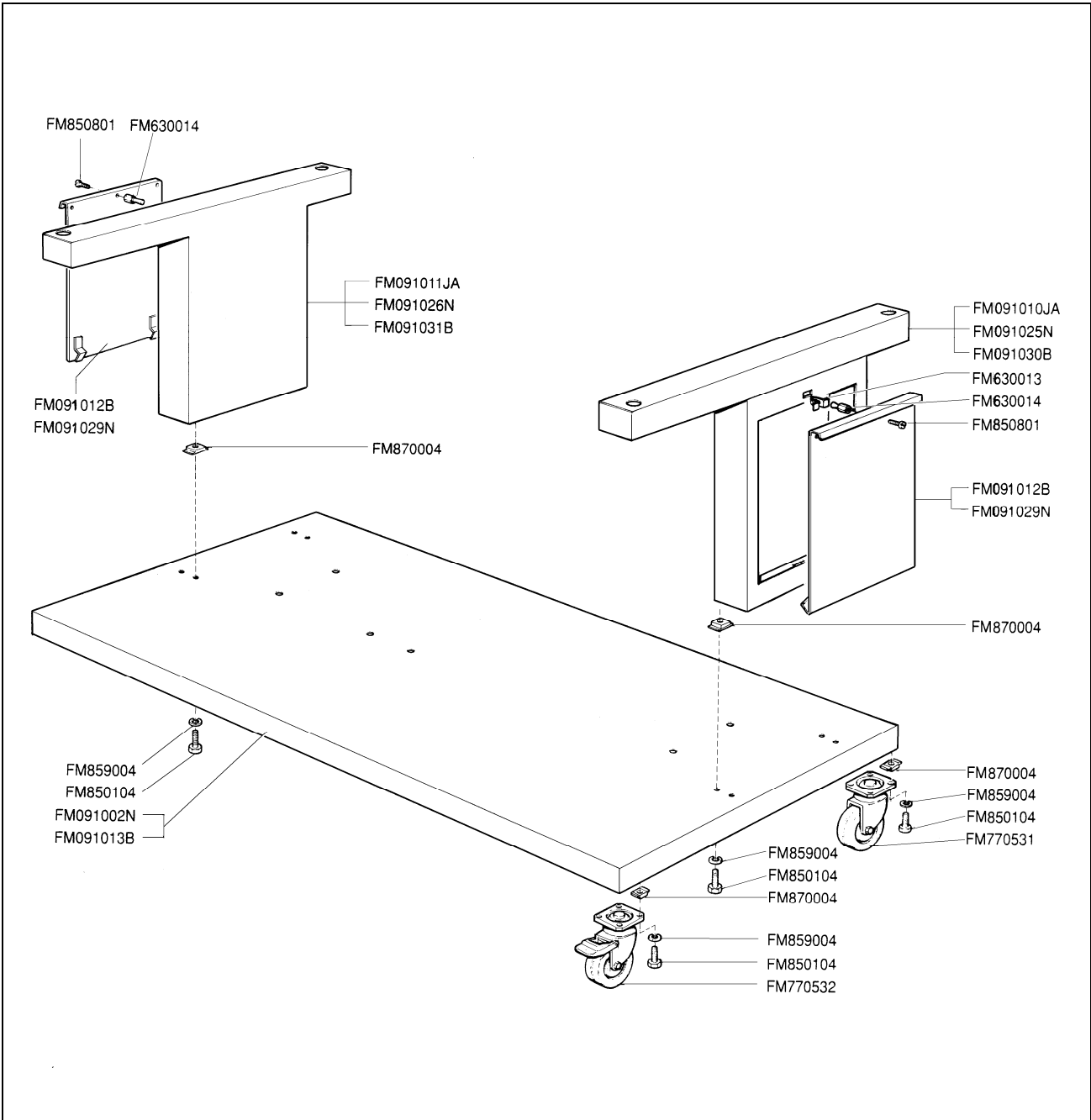



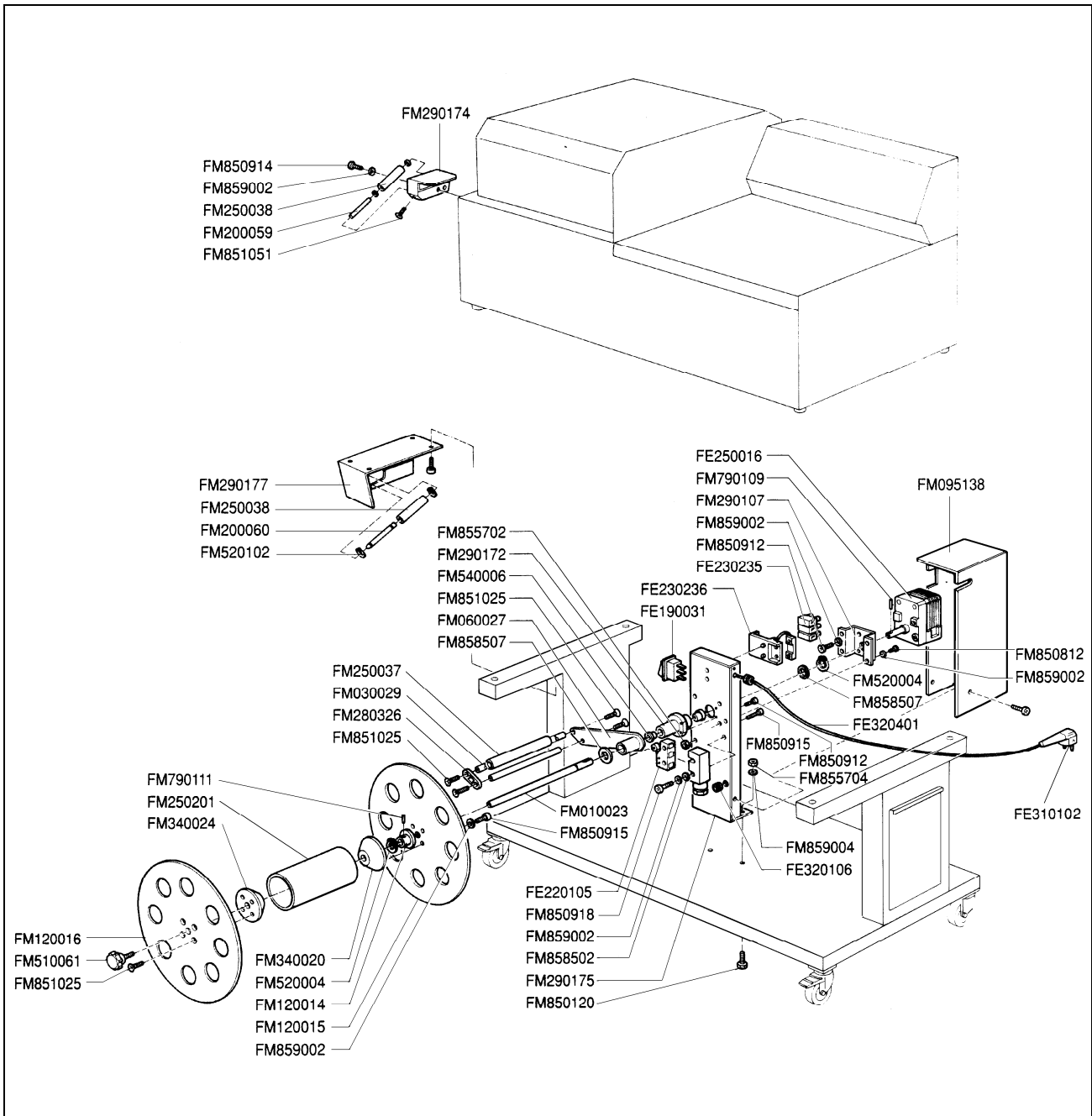

## SCHEMA ELETTRICO / WIRING DIAGRAM

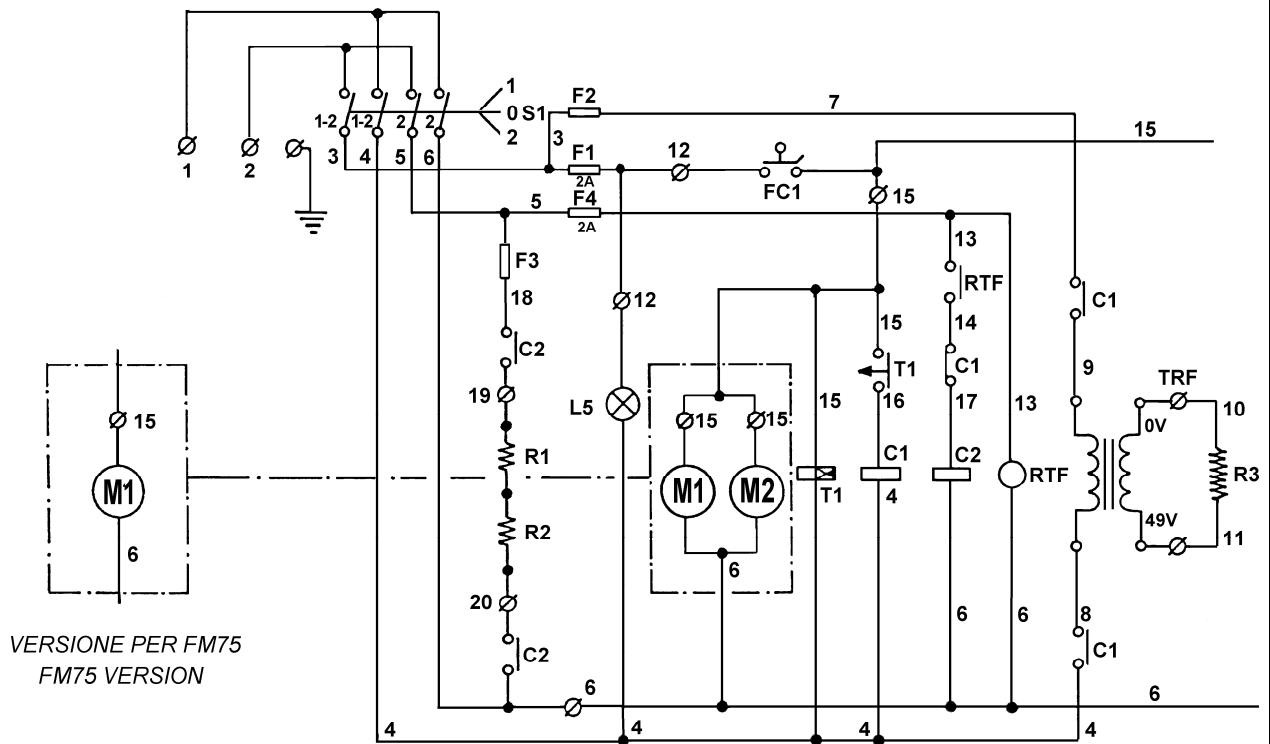

1 2 10 11 19 20 6 12 15 15 FM 75

1 2 10 11 19 20 6 6 12 15 15 15 FM 76

MINIPACK FM 75 FM76 220V. 50 HZ

<b>S1</b>	Selettore ciclo	Cycle selector
<b>C1</b>	Contattore trasformatore taglio	Cutting blade contactor
<b>C2</b>	Contattore resistenze	Heaters contactor
<b>RTF</b>	Termoregolatore	Thermoregulator
<b>T1</b>	Temporizzatore taglio	Cutting blade timer
<b>LS</b>	Spie tensione macchina	Light
<b>TRF</b>	Trasformatore taglio	Cutting blade transformer
<b>FC1</b>	Finecorsa ciclo macchina	Machine control limit
<b>M1</b>	Motore ventilazione 1	Fan motor 1
<b>M2</b>	Motore ventilazione 2 (solo per FM76)	Fan motor 2 (only for FM76)
<b>R1</b>	Resistenza	Heater
<b>R2</b>	Resistenza	Heater
<b>R3</b>	Resistenza di taglio	Cutting resistance
<b>F1</b>	Fusibile 2A	Fuse 2A
<b>F2</b>	Fusibile 16A	Fuse 16A
<b>F3</b>	Fusibile 16A	Fuse 16A
<b>F4</b>	Fusibile 2A	Fuse 2A



***Minipack-torre S.p.A.***

*Via Provinciale, 54 - 24044 DALMINE (BG) - ITALY*

*Tel. (035) 563525 – Fax (035) 564945*

*E-mail: [info@minipack-torre.it](mailto:info@minipack-torre.it)*

*Internet: [www.minipack-torre.it](http://www.minipack-torre.it)*