



Minipack-torre S.p.A.
Via Provinciale, 54 - 24044 Dalmine (BG) - Italy
Tel. (035) 563525 – Fax (035) 564945
E-mail: info@minipack-torre.it
[http:// www.minipack-torre.it](http://www.minipack-torre.it)



RP85

Catalogo ricambi

(Valido dalla matricola nr. 790 del 04.2010 fino alla matricola nr. 2900 del 05.2012)

Spare parts catalogue

(Valid from serial number 790 dated 04.2010 up to 2900 dated 05.2012)

REV.01: Le modifiche introdotte sono: nuovo dissipatore potenziato da 2100W;
nuovo termostato di sicurezza (FE430006).

REV.01: On these machines we installed the following new parts: more powerful heat sink 2100W;
new safety thermostat (FE430006).

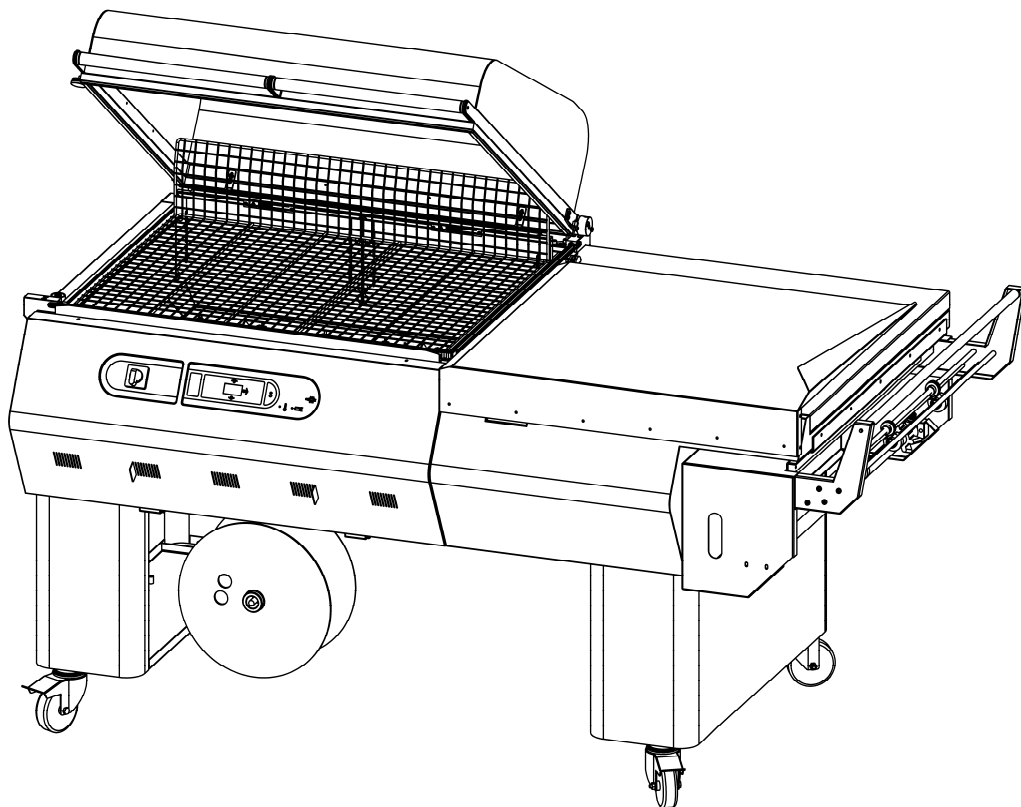

CONSULTARE ATTENTAMENTE QUESTO CATALOGO PRIMA DI ORDINARE PEZZI DI RICAMBIO
CAREFULLY READ THIS CATALOGUE BEFORE ORDERING ANY SPARE PART



DOC. N. FM112171
REV. 01
Ed: 07.2012

УПАКОВОЧНОЕ ОБОРУДОВАНИЕ



ПРОИЗВОДСТВО И ПОСТАВКА
СЕРВИСНЫЙ РЕМОНТ
ЗАПАСНЫЕ ЧАСТИ
РАСХОДНЫЕ МАТЕРИАЛЫ

Диагностика, ремонт, сервисное обслуживание.

Запасные части и расходный материал: резина, тефлоновая лента, термонож (лезвие), гель для смазки.

Плѐнка термоусадочная полиолефиновая.

Система «Trade-In» – замена Вашего оборудования на новое и более производительное.



На фото: запайщик Magnetic FL900 + туннель Magnetic T100

ООО «АРДсистемы»

(495) 231-21-00

(812) 363-20-22

info@ardsystems.ru

www.filmtrade.ru

www.ardsystems.ru

LEGENDA PARTICOLARI / ITEMS DESCRIPTION**TAVOLA 1 / SCHEME 1**

Pos. Pos.	Codice Code	Descrizione Description
1.02	S0K00303	Kit morsetto anteriore / Front clamp kit
1.03	S0K00304	Kit morsetto posteriore / Rear clamp kit
1.04	S03A0306	Kit morsetto centrale portalama / Blade holder central clamp kit
1.05	S03A0309	Kit profilati porta isolatori / Infill holder channel kit
1.06	S03A0901	Kit protezione antinfortunistica anteriore / Front guard kit
1.07	S03A0902	Kit protezione antinfortunistica laterale / Side guard kit
1.08	S03A0310	Kit isolatori / Infill blocks kit
1.09	KR030001	Lama saldante teflonata / Teflon-coated sealing blade
1.10	FM220269	Profilato porta gomma laterale inferiore / Lower rubber holder side channel
1.11	FM350007	Gomma neoprene 15X10 Lg.720 / 15X10 Lg.720 Neoprene rubber
1.12	FM281521	Paletta polmone calore / Heating chamber flap
1.13	FM091186	Rinforzo posteriore / Rear reinforcement
1.14	FM195116	Pannello lana di roccia / Rock wool panel
1.15	KR310A02	Kit dissipatore polmone calore W2100 V230 / W2100 V230 Heat sink kit
	KR310D02	Kit dissipatore polmone calore W2100 V200-208 / W2100 V200-208 Heat sink kit
	KR350B03	Kit dissipatore polmone calore W2100 V400 / W2100 V400 Heat sink kit
1.15.01	FM390014	Dissipatore polmone calore W2100 V230 / W2100 V230 Heat sink
	FM390013	Dissipatore polmone calore W2100 V200-208 / W2100 V200-208 Heat sink
	FM390012	Dissipatore polmone calore W2100 V400 / W2100 V400 Heat sink
1.15.02	FE435011	Termocoppia / Thermocouple
1.16	KR350A04	Kit dissipatore sx polmone calore W2100 V230 / W2100 V230 Left heat sink kit
	KR350D04	Kit dissipatore sx polmone calore W2100 V200-208 / W2100 V200-208 Left heat sink kit
	KR350B04	Kit dissipatore sx polmone calore W2100 V400 / W2100 V400 Left heat sink kit
1.16.01	FM390014	Dissipatore polmone calore W2100 V230 / W2100 V230 Heat sink
	FM390013	Dissipatore polmone calore W2100 V200-208 / W2100 V200-208 Heat sink
	FM390012	Dissipatore polmone calore W2100 V400 / W2100 V400 Heat sink
1.17	FM091034	Piastra posteriore resistori / Heaters rear plate
1.18	FM110552	Targhetta alta temperatura / High temperature plate
1.19	FM091038	Piastra anteriore resistori / Heaters front plate
1.20	FM195115	Pannello lana di vetro / Glass wool panel
1.21	FE430006	Termostato di sicurezza / Safety thermostat

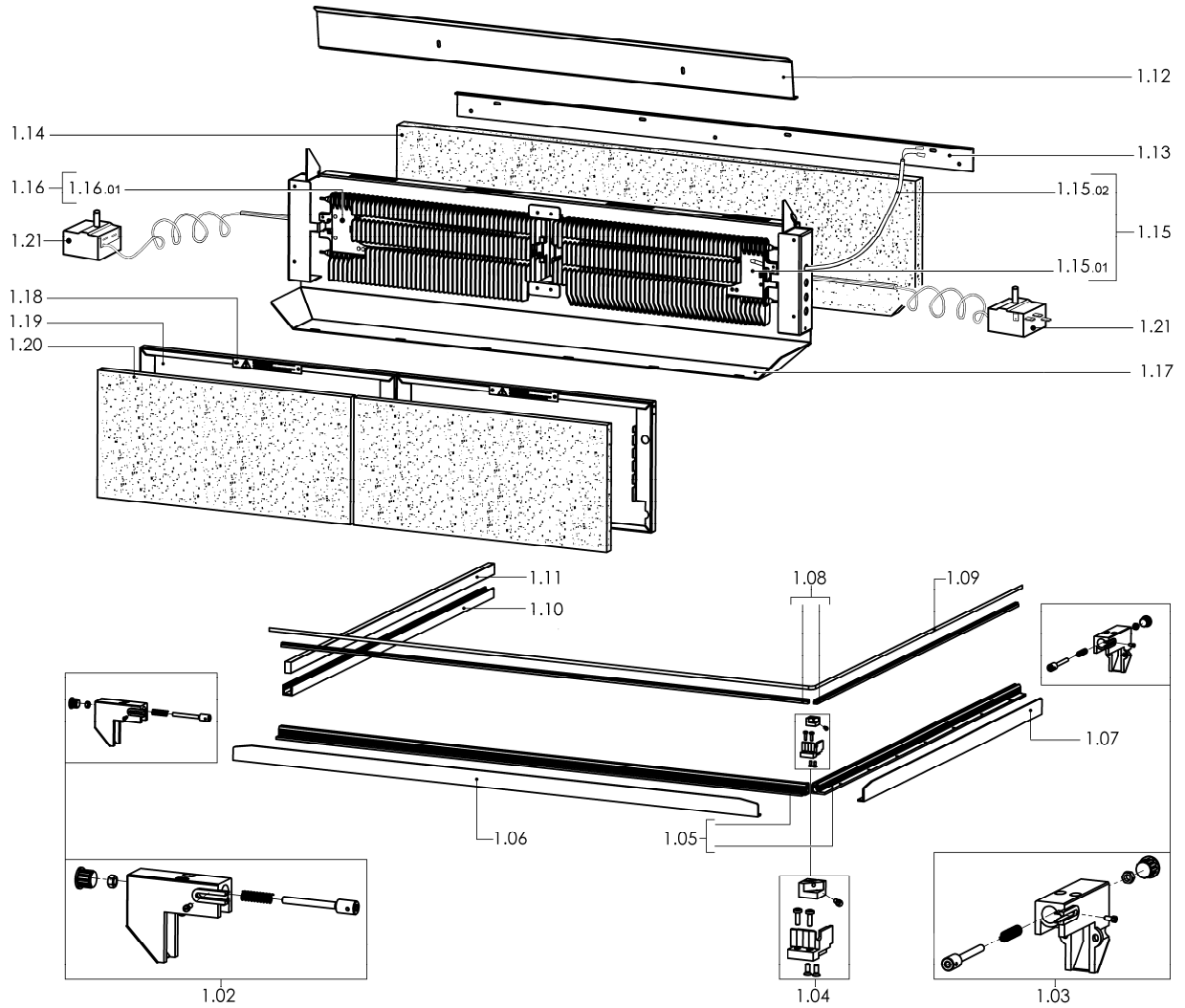

LEGENDA PARTICOLARI / ITEMS DESCRIPTION**TAVOLA 2 / SCHEME 2**

Pos. Pos.	Codice Code	Descrizione Description
2.01	GOK00011	Kit ammortizzatore campana / Hood shock absorber kit
2.02	SOK01002	Kit perno rotazione campana / Hood rotation pin kit
2.03	FM290101	Supporto campana / Hood support
2.04	FM170003	Barra di torsione / Torsion bar
2.05	FM250103	Tube per barra di torsione / Torsion bar tube
2.06	FM340100	Bussola per barra torsione / Torsion bar bush
2.07	S03A1004	Kit alloggiamento barra di torsione / Torsion bar housing kit
2.08	KR030002	Kit teflon / Teflon kit
2.09	FM350010	Gomma neoprene 17X10 L.3190mm / Neoprene rubber 17X10 L.3190mm
2.10	KR350053	Kit profilati porta gomma superiore / Upper rubber holder channels kit
2.11	S03A0402	Kit maniglia x campana / Handgrip kit x hood
2.12	SOK00406	Kit tastatore microinterruttore / Microswitch screw kit
2.13	SOK01001	Kit flangia bloccaggio barra torsione / Torsion bar blocking flange kit
2.14	FM540007	Bussola / Bush
2.15	SOK00405	Kit levetta apertura paletta / Heating chamber flap opening lever kit
2.16	FM300248	Telaio per campana superiore / Upper hood frame
2.17	FM081030 FM081035 FM081036	Campana superiore h.200mm (standard) / Upper hood h.200mm (standard) Campana superiore h.300mm (optional) / Upper hood h.300mm (optional) Campana superiore h.490mm (optional) / Upper hood h.490mm (optional)
2.18	FM852207	Vite STEI M4X14 / M4X14 screw
2.19	MR350001	Gruppo magnete retrazione (standard) / Magnet pressing group (standard)
2.19.01	FM160026	Contrasto per elettromagnete / Electromagnet contrast
2.19.02	FM350011	Rondella contrasto elettromagnete / Electromagnet contrast washer
2.19.03	FM280011	Squadretta per contrasto elettromagnete / Electromagnet contrast square
2.19.04	FE130013	Elettromagnete / Electromagnet
2.20	MS310001	Gruppo magnete saldatura (optional) / Sealing magnet group (optional)
2.20.01	FM290156	Supporto contrasto magnete / Magnet contrast support
2.20.02	FM170105	Molla a compressione / Compression spring
2.20.03	FM200065	Perno contrasto elettromagnete / Electromagnet contrast pin
2.20.04	FM160032	Contrasto elettromagnete / Electromagnet contrast
2.20.05	FE130010	Elettromagnete / Electromagnet
2.20.06	FM290155	Supporto magnete / Magnet support

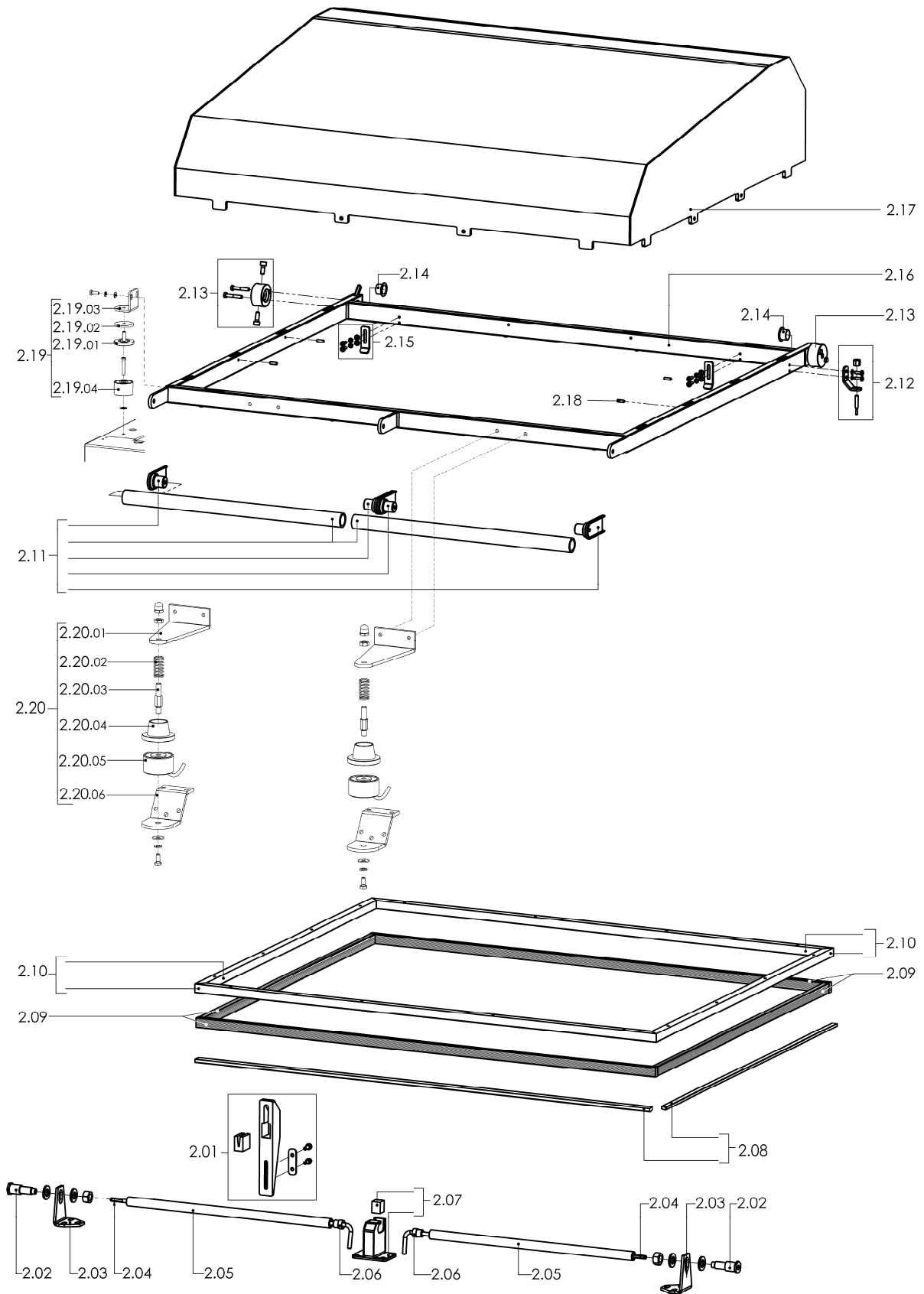

LEGENDA PARTICOLARI / ITEMS DESCRIPTION**TAVOLA 3 / SCHEME 3**

Pos. Pos.	Codice Code	Descrizione Description
3.01 3.01.01 3.01.02	PC35B001 FM090178 FM300003	Prem.piatto di confezionamento RAL7035B. / RAL7035B. packaging plate pre-assembly Piatto di confezionamento RAL7035B. / RAL7035B. packaging plate Telaio piatto di confezionamento / Packaging plate frame
3.01.01	FM090162	Piatto di confezionamento inox (optional) / Inox packaging plate (optional)
3.02	PB35B001	Premontaggio supporto bobina RAL7035B. / RAL7035B. roll support pre-assembly
3.03	FM091190	Supporto bobina RAL7035B. / RAL7035B. roll support
3.04	FM030021	Astina per microforatore / Microperforator rod
3.05	FM710318	Rullo di rinvio / Film drive roller
3.06	S03A0605	Kit rotellina con aghi / Microperforator with needles kit
3.07	S0K00608	Kit rotellina con cava / Slotted microperforator kit
3.08	FM340525	Supporto per rullo porta bobina / Reel holder roller support
3.09	S03A0602	Kit tubo porta bobina / Film roll tube kit
3.10	FM220501	Angolare guida supporto bobina / Roll support guide corner
3.11	FM660002	Carrello con ruota / Wheeled trolley

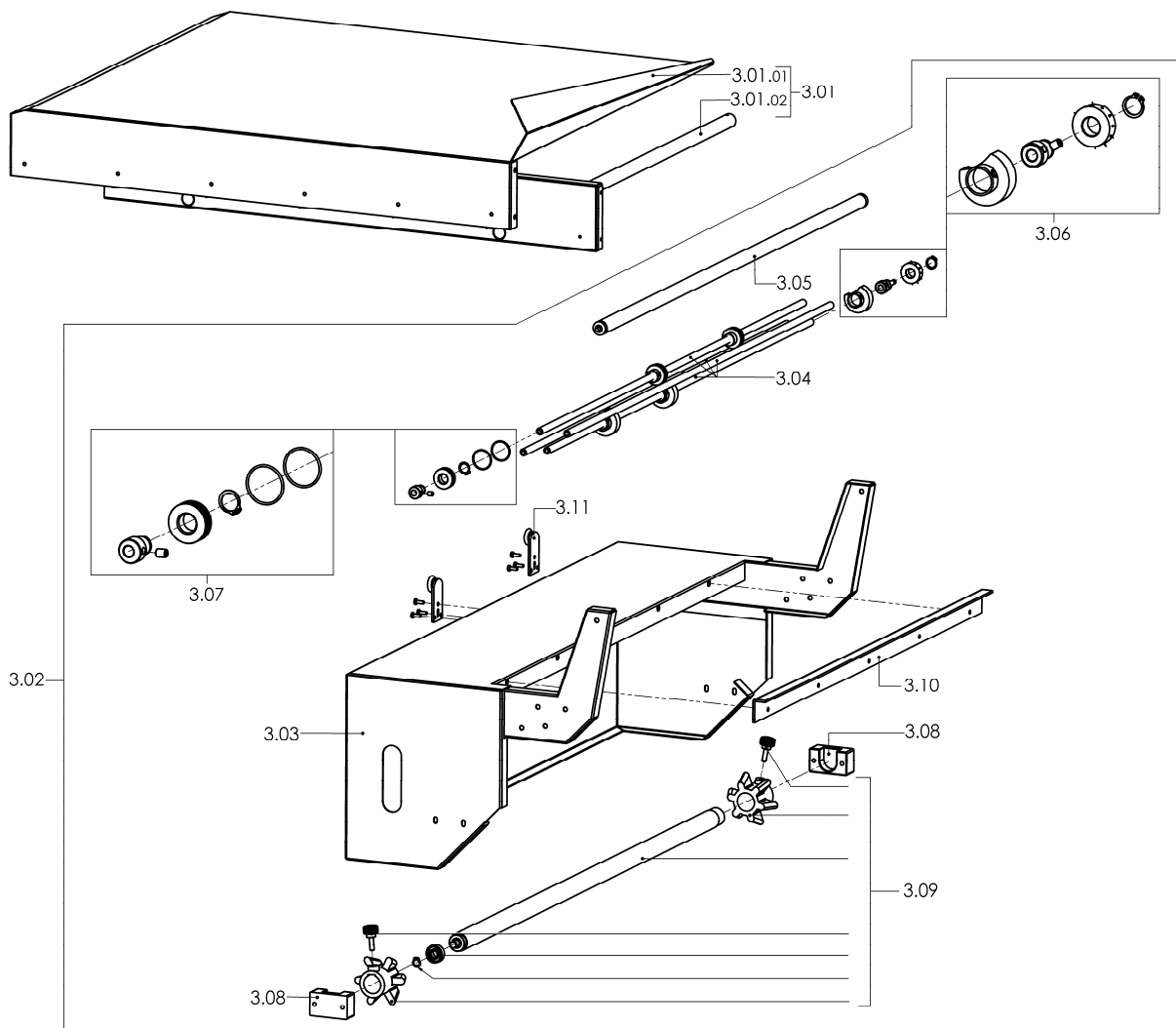

**LEGENDA PARTICOLARI / ITEMS DESCRIPTION
(Optional)****TAVOLA 3.1 / SCHEME 3.1**

Pos. Pos.	Codice Code	Descrizione Description
3.02	PB35B002	Premontaggio supporto bobina lungo RAL7035B. / RAL7035B. larger roll support pre-assembly
3.03	FM091199	Supporto bobina lungo RAL7035B. / RAL7035B. larger roll support
3.04	FM030035	Astina per microforatore / Microperforator rod
3.05	FM710313	Rullo di rinvio / Film drive roller
3.06	S03A0605	Kit rotellina con aghi / Microperforator with needles kit
3.07	S0K00608	Kit rotellina con cava / Slotted microperforator kit
3.08	FM340525	Supporto per rullo porta bobina / Reel holder roller support
3.09	No code	Kit tubo porta bobina / Film roll tube kit
3.10	FM220501	Angolare guida supporto bobina / Roll support guide corner
3.11	FM660002	Carrello con ruota / Wheeled trolley

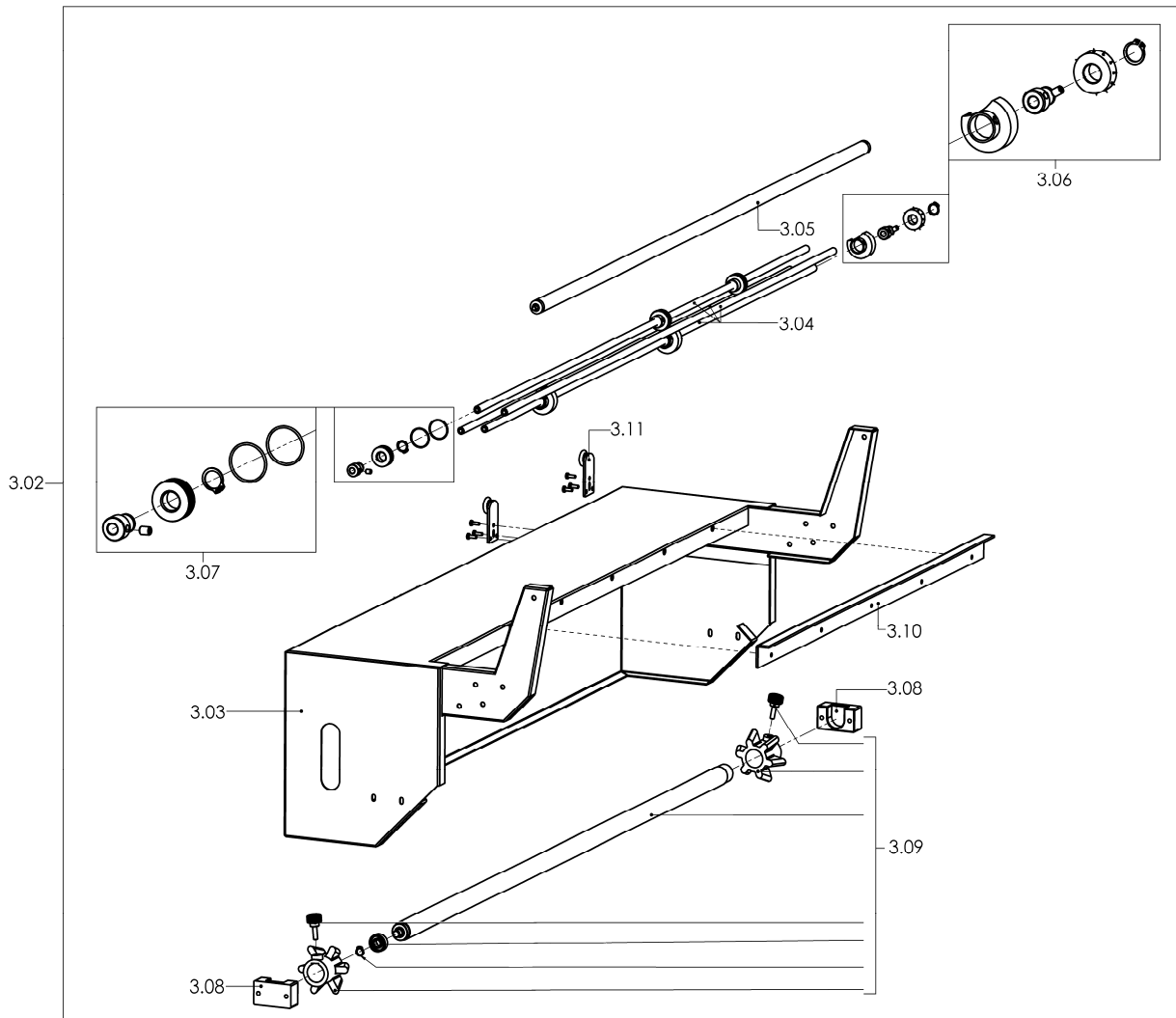

LEGENDA PARTICOLARI / ITEMS DESCRIPTION**TAVOLA 4 / SCHEME 4**

Pos. Pos.	Codice Code	Descrizione Description
4.01	FM300018	Traversa / Crosspiece
4.02	FM300141	Traversa per avvolgitore / Rewinder crosspiece
4.03	FM090665	Copertura di fondo destra / Right lower cover
4.04	FM090627	Copertura di fondo centrale / Central lower cover
4.05	FM090626	Copertura di fondo sinistra / Left lower cover
4.06	FE240004 FE240005 FE240006	Motore 200V 50Hz 3F. / Motor 200V 50Hz 3Ph Motore 208V 60Hz 3F. / Motor 208V 60Hz 3Ph Motore 230-400V 50Hz 3F. / Motor 230-400V 50Hz 3Ph
4.07	FM091033	Campana inferiore / Lower hood
4.08	FM091193	Carenatura RAL7035B. / RAL7035B. fairing
4.09	FM140001	Profilato "ROLLGE 150" / "ROLLGE 150" channel
4.10	FM220501	Angolare per guida / Guide corner
4.11	FM230002	Protezione per microinterruttore / Microswitch guard
4.12	S0K01208	Kit microinterruttore campana / Hood microswitch kit
4.13	S0K01120	Kit ventola / Fan kit
4.14	FE120257 FE120262	Scheda di potenza (400V) / Power board (400V) Scheda di potenza (200-208-230V) / Power board (200-208-230V)
4.14.01	FE290405 FE290402	Fusibile 10.3X38 AM 10A (200-208-230V) / Fuse 10.3X38 AM 10A (200-208-230V) Fusibile 10.3X38 AM 4A (400V) / Fuse 10.3X38 AM 4A (400V)
4.14.02	FE290409 FE290407	Fusibile 10.3X38 AM 25A (200-208-230V) / Fuse 10.3X38 AM 25A (200-208-230V) Fusibile 10.3X38 AM 16A (400V) / Fuse 10.3X38 AM 16A (400V)
4.14.03	FE290402 FE290401	Fusibile 10.3X38 AM 4A (200-208-230V) / Fuse 10.3X38 AM 4A (200-208-230V) Fusibile 10.3X38 AM 2A (400V) / Fuse 10.3X38 AM 2A (400V)
4.15	FE120261	Scheda di comando / Control board
4.16	FE080001 FE080000	Interruttore 20A (400V) / Switch 20A (400V) Interruttore 32A (200-208-230V) / Switch 32A (200-208-230V)
4.17	FM091188	Frontale RAL7035B. / RAL7035B. front panel
4.18	FM110340	Adesivo pulsantiera / Push button panel adhesive
4.19	FE120601	Tastiera a membrana / Membrane keyboard
4.20	FM510084	Cerniera / Hinge
4.21	FM091148	Pannello posteriore RAL7035B. / RAL7035B. rear panel
4.22	FM130003	Piatto retinato / Reticulated plate
4.23	FE440026 FE440025	Trasformatore 400VA (400V) / Transformer 400VA (400V) Trasformatore 400VA (200-208-230V) / Transformer 400VA (200-208-230V)
4.24	FE440628 FE440627	Trasformatore 2500VA (400V) / Transformer 2500VA (400V) Trasformatore 2500VA (200-208-230V) / Transformer 2500VA (200-208-230V)
4.25	FM095796	Supporto macchina sinistro RAL7035B. / RAL7035B. machine left support
4.26	FM095794	Supporto macchina destro RAL7035B. / RAL7035B. machine right support
4.27	FM770510	Ruota Ø100 con freno / Wheel Ø100 with brake
4.28	FM770509	Ruota Ø100 / Wheel Ø100
4.29	S03A1301	Kit supporti anteriori piatto retinato / Screened plate front support

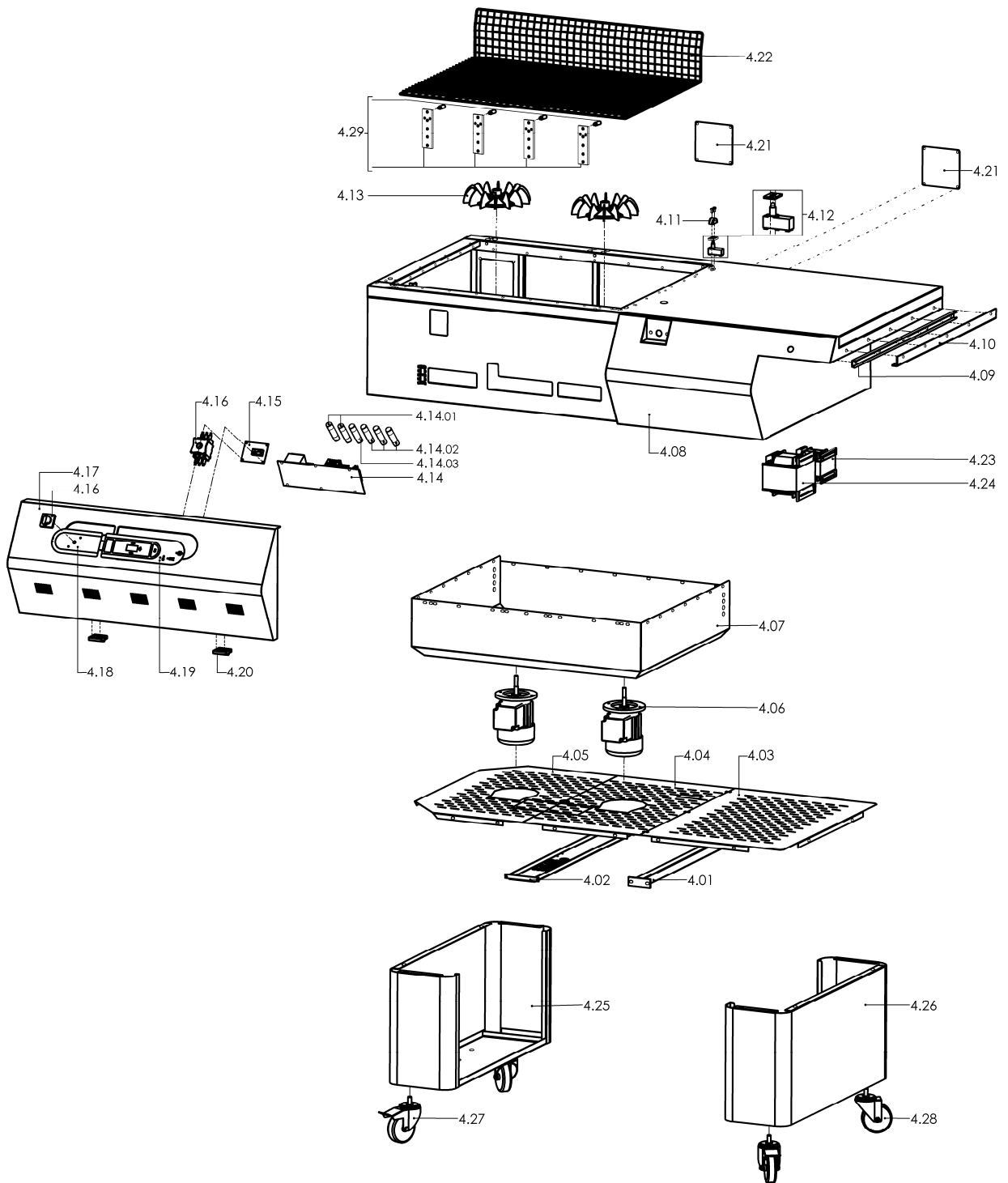

**LEGENDA PARTICOLARI / ITEMS DESCRIPTION
(Optional)****TAVOLA 5 / SCHEME 5**

Pos. Pos.	Codice Code	Descrizione Description
5.01	AV030003	Gruppo avvolgitore (optional) / Rewinder group (optional)
5.02	FE310120	Cavo 3X0,75X1500 / Cable 3X0,75X1500
5.03	FE190032	Interruttore / Switch
5.04	FM010041	Albero avvolgitore film / Film rewinder shaft
5.05	FM160111	Rondella / Washer
5.06	FE220105	Microinterruttore / Microswitch
5.07	FM290175	Supporto avvolgitore / Rewinder support
5.08	FM160104	Ghiera / Ring nut
5.09	FM170161	Molla / Spring
5.10	FM120040	Flangia mobile / Movable flange
5.11	FM250128	Mozzo / Hub
5.12	FM120041	Flangia fissa / Fixed flange
5.13	FM280326	Piastrina / Plate
5.14	FM250074	Rullo / Roller
5.15	FM030063	Asta / Rod
5.16	FM060027	Leva / Lever
5.17	FM290172	Supporto leva / Lever support
5.18	FE220101	Protezione microinterruttore / Microswitch guard
5.19	FM290107	Supporto motoriduttore / Gearmotor support
5.20	FE250016	Motoriduttore / Gearmotor
5.21	FM095138	Carter / Case
5.22	FM160231	Anello guida film / Film guiding ring
5.23	FM290525	Squadretta anello guida film / Film guiding ring square
5.24	FM160231	Anello guida film / Film guiding ring
5.25	S0K00407	Kit guida a piolo per film / Film guide kit

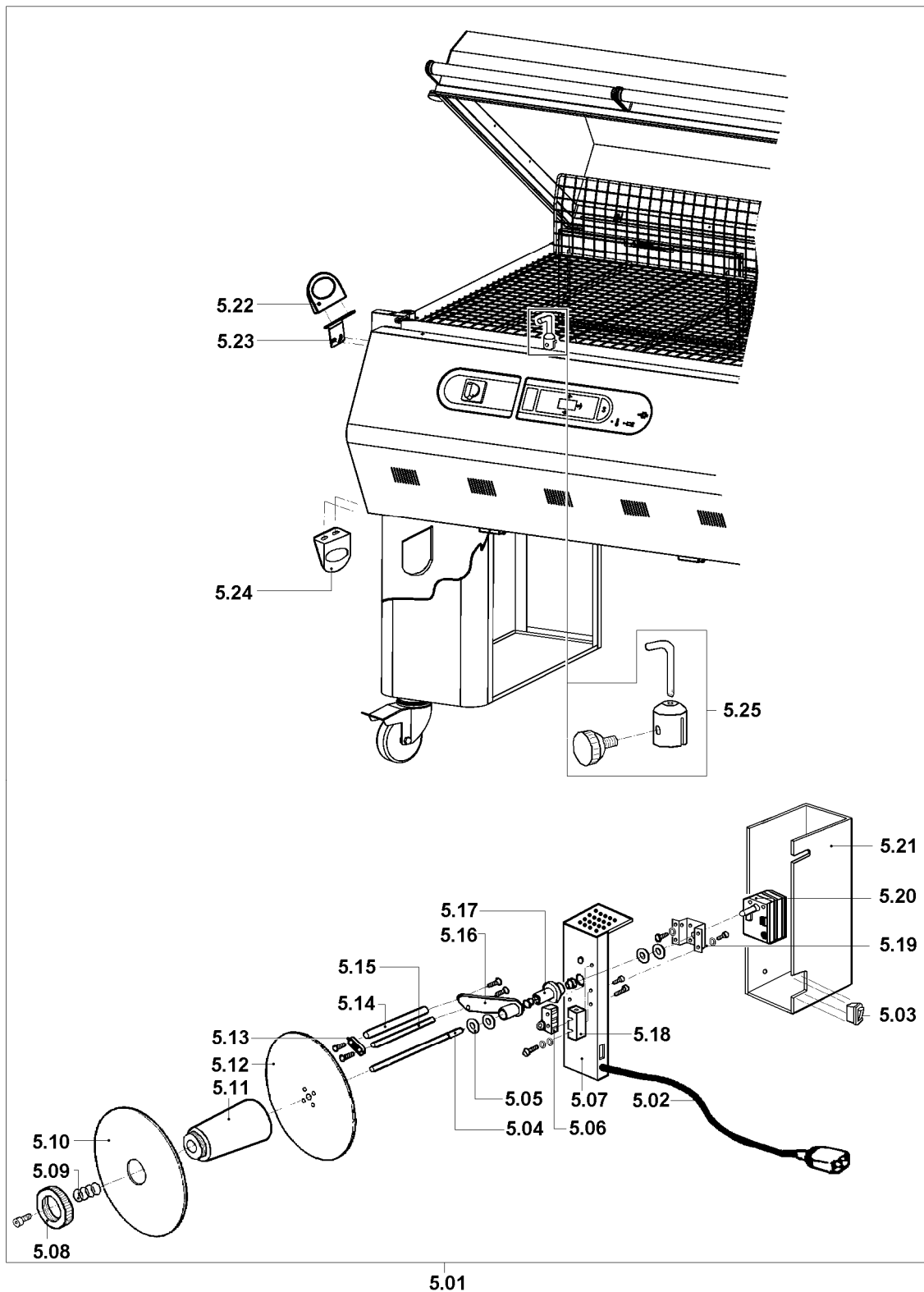

SCHEMA ELETTRICO 200-208-230-400V / WIRING DIAGRAM 200-208-230-400V

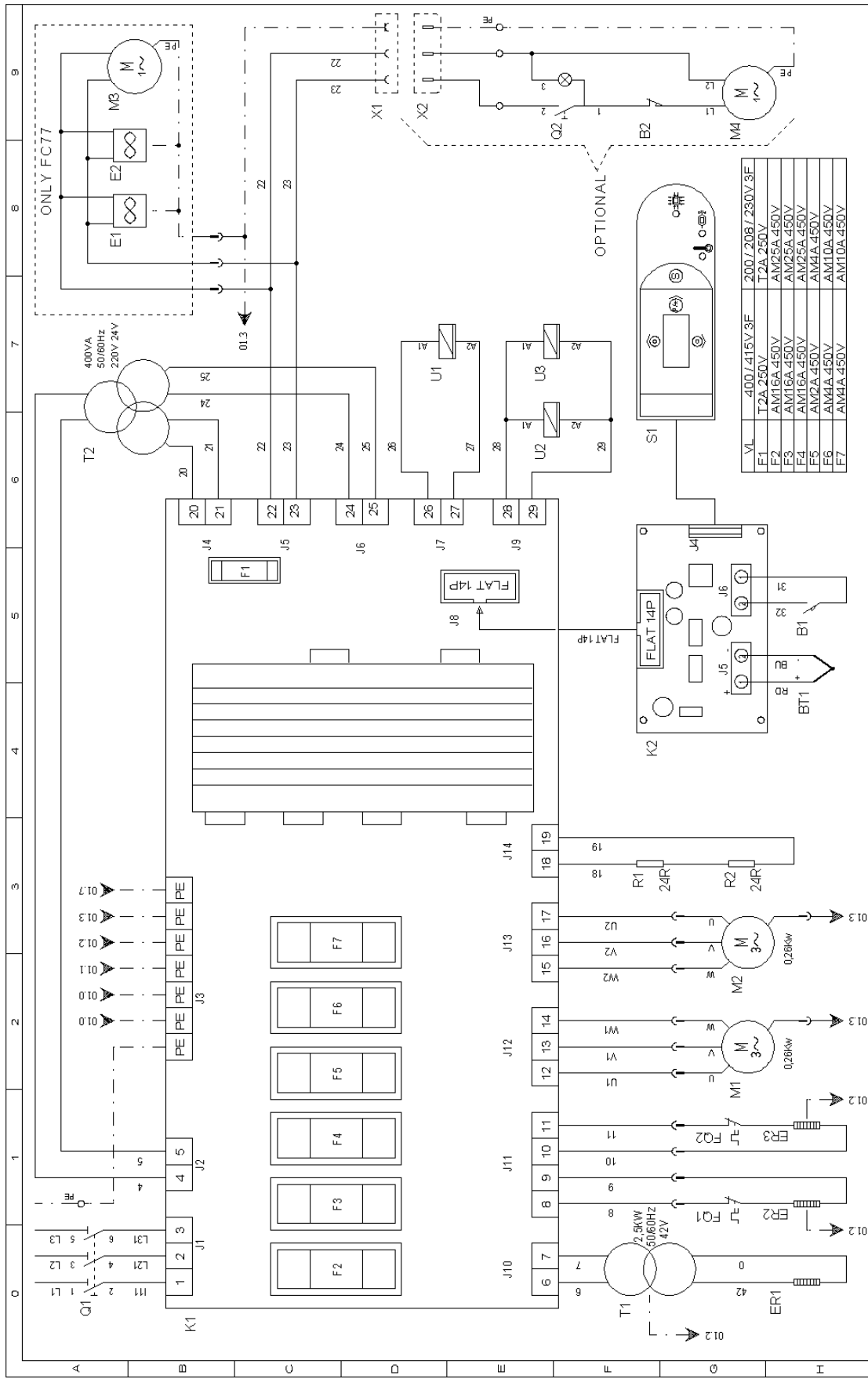

PROGETTO:	FOGLIO 01		
CODICE:	DI 01		
DESEGNOR NR: WDMF3501			
TITOLO: SCHEMA DI POTENZA			
DESEGNATORE: Boldoni	DATA: 17/06/2009		
REV	DATA	FIRMA	MODIFICA

LEGENDA SCHEMA ELETTRICO / WIRING DIAGRAM DESCRIPTION

B1	Finecorsa start ciclo / Cycle start limit switch
B2	Finecorsa avvolgitore / Rewinder limit switch
BT1	Termocoppia / Thermocouple
E1/2	Ventilatore raffreddamento / Cooling fan
E3	Ventilatore raffreddamento / Cooling fan
ER1	Resistenza lama saldante / Sealing blade heater
ER2/3	Resistore di retrazione / Shrinking heater
FQ1/2	Termostato di sicurezza / Safety thermostat
F1	Fusibile ventilatore, pompa raffreddamento, avvolgitore 5X20 / Ventilator, cooling pump, rewinder fuse 5X20
F2/3/4	Fusibile linea 10.3X38 / Line fuse 10.3X38
F5	Fusibile trasformatore ausiliario 10.3X38 / Auxiliary transformer fuse 10.3X38
F6/7	Fusibile motore ventola 10.3X38 / Fan motor fuse 10.3X38
K1	Scheda di potenza / Power board
K2	Scheda di comando / Control board
M1/2	Motore ventola / Fan motor
M3	Motore pompa di raffreddamento / Cooling pump motor
M4	Motore avvolgitore / Rewinder motor
Q1	Interruttore generale / Motor brake resistor
Q2	Interruttore avvolgitore / Motor brake resistor
R1	Resistore per freno motore / Main switch
R2	Resistore per freno motore / Rewinder switch
S1	Tastiera a membrana / Membrane keyboard
T1	Trasformatore di taglio / Cutting transformer
T2	Trasformatore ausiliario / Auxiliary transformer
U1	Magnete di retrazione / Shrinking magnet
U2/3	Magnete di saldatura / Sealing magnet
X1	Presenza alimentazione avvolgitore / Rewinder power supply socket
X2	Spina alimentazione avvolgitore / Rewinder power supply plug



Minipack-torre S.p.A.

Via Provinciale, 54 - 24044 DALMINE (BG) - ITALY

Tel. (035) 563525 – Fax (035) 564945

E-mail: info@minipack-torre.it

Internet: www.minipack-torre.it