

УПАКОВОЧНОЕ ОБОРУДОВАНИЕ



ПРОИЗВОДСТВО И ПОСТАВКА
СЕРВИСНЫЙ РЕМОНТ
ЗАПАСНЫЕ ЧАСТИ
РАСХОДНЫЕ МАТЕРИАЛЫ

Диагностика, ремонт, сервисное обслуживание.

Запасные части и расходный материал: резина, тефлоновая лента, термонож (лезвие), гель для смазки.

Плѐнка термоусадочная полиолефиновая.

Система «Trade-In» – замена Вашего оборудования на новое и более производительное.



На фото: запайщик Magnetic FL900 + туннель Magnetic T100

ООО «АРДсистемы» (495) 231-21-00
(812) 363-20-22
info@ardsystems.ru

www.filmtrade.ru www.ardsystems.ru

COMECONSULTAREILCATALOGODELLEPARTIDIRICAMBIO

METHOD TO CONSULT SPARE PARTS MANUAL - WIE MAN DEN ERSATZTEILKATALOG SOLL

COMMENT CONSULTER LE CATALOGUE DES PIECES DE RECHANGE - COMO CONSULTAR EL CATALOGO DE LAS PIEZAS DE RECAMBIO

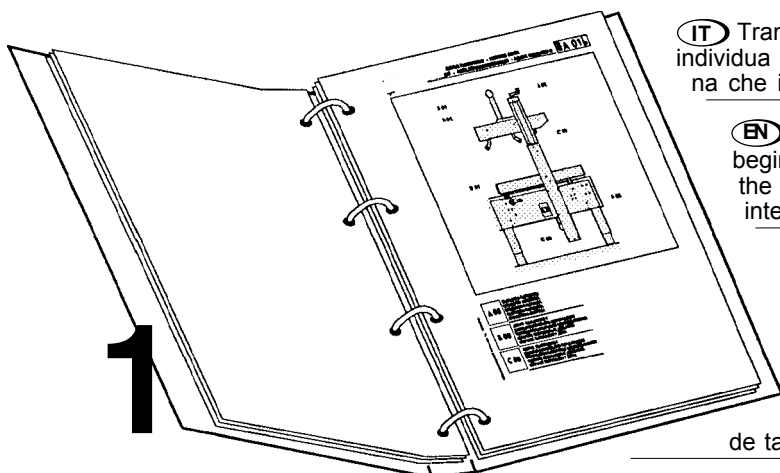

IT Tramite l'indice figurativo, posto all'inizio del catalogo, si individua il numero di tavola relativa alla parte della macchina che interessa.

EN By means of the picture index placed at the beginning of the catalogue you find out the number of the table representing the machine part you are interested in.

DE Durch das Abbildungsverzeichnis, das sich am Anfang des Katalogs befindet, stellt man die Tafelnummern, die das Maschinenteil darstellt, das uns interessiert.

FR Par l'intermédiaire de l'indice figuratif, placé au début du catalogue, on repère le n° de table relatif à la partie de la machine intéressée.

ES Por medio del índice figurativo, que se encuentra al inicio del catálogo, se individua el número de tabla relativo a la parte de la máquina que interesa.

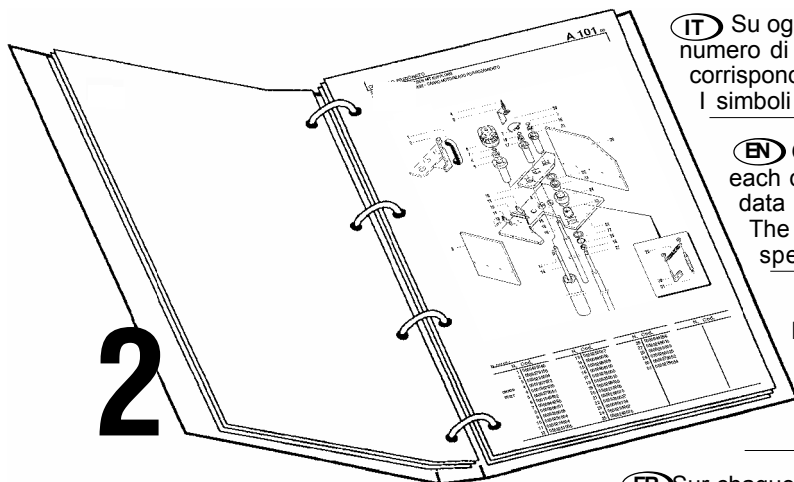

IT Su ogni tavola, ad ogni particolare è attribuito un numero di riferimento. Nella tabella, ad ogni riferimento corrispondono tutti i dati necessari per l'ordinazione. I simboli rappresentano alcune specifiche di costruzione.

EN On each table, a reference number is assigned to each detail. In the table, each reference provides all data necessary for ordering. The symbols represent some manufacturing specifications.

DE In jeder Tafel werden alle Teile mit einer Bezugsnummer gekennzeichnet. In der Tabelle werden unter jeder Bezugsnummer alle für die Bestellung wichtigen Daten angegeben. Mit den Zeichen werden Angaben zur Konstruktion gemacht.

FR Sur chaque planche, on a indiqué un numéro de repère pour chaque pièce. Sur le tableau, à côté de chaque repère on a indiqué toutes les données nécessaires pour commander les pièces. Les symboles représentent des spécifications de fabrication.

ES En cada lámina, a cada ítem se le atribuye un número de referencia. En la tabla, a cada referencia, corresponden todos los datos necesarios para la formulación del pedido. Los símbolos son representativos de algunos detalles de fabricación.

SIMBOLI • SYMBOLS • SYMBOLE • SYMBOLES • SIMBOLO

Dx **Particolare destro**
Right-hand part
Rechter Teil
Pièce droite
Particular derecho

Indica più modelli, più versioni
Indicates more models, more versions
Indique plusieurs modèles, plusieurs variantes
Gibt mehrere Modelle, mehrere Versionen an
Indica más modelos, más versiones

Assieme gruppo
Assembly
Ensemble, groupe
Satz, Gruppe
Conjunto grupo

Sx **Particolare sinistro**
Left-hand part
Linker Teil
Pièce gauche
Particular izquierdo

Codici riportati in tabella
Codes indicated in the table
Codes indiqués sur la table
In der Tabelle aufgeführte Codes
Código referido en la tabla

Note generali
General notes
Allgemeine Hinweise
Notes générales
Notas generales

OPT **Optional**
Optional
Option
Wahlweiser Teil
Optional

NORME PER LE ORDINAZIONI

HOW TO PLACE AN ORDER - RICHTLINIE FÜR BESTELLUNGEN
MODE DE COMMANDE - NORMAS PARA LAS ORDENACIONES

IT LE ORDINAZIONI DELLE PARTI DI RICAMBIO DEVONO ESSERE CORREDATE DALLE SEGUENTI INDICAZIONI:

- 1) Modello macchina (rif. A)
- 2) Matricola (rif. B)
- 3) Anno di costruzione (rif. C)
- 4) Numero della tavola
- 5) Numero di riferimento del particolare
- 6) Numero di codice del particolare
- 7) Quantità richiesta
- 8) Modo di spedizione

Per i componenti colorati specificare il colore desiderato.

NOTA:

Effettuare la richiesta dei ricambi compilando l'apposita scheda in ogni sua parte.

EN WHEN ORDERING SPARES, PLEASE ALWAYS SUPPLY THE FOLLOWING INFORMATION:

- 1) Machine type (rif. A)
- 2) Serial number (rif. B)
- 3) Year of manufacture (rif. C)
- 4) Table number
- 5) Item reference number
- 6) Item code
- 7) Required quantity
- 8) Way of shipment

For the colored components, specify the color.

NOTE:

Pls order spare parts by filling up the proper form in each part.

DE DIE BESTELLUNGEN DER ERSATZTEILE MÜSSEN MIT FOLGENDEN DATEN VERSEHEN SEIN:

- 1) Maschinenmodell (Punkt A)
- 2) Seriennummer (Punkt B)
- 3) Herstellungsjahr (Punkt C)
- 4) Bildtafelnummer
- 5) Bezugsnummer des Teiles
- 6) Codenummer des Teiles
- 7) Angeforderte Menge
- 8) Versandart

Bei farbigen Teilen, immer die Farbe angeben.

ANMERKUNG:

Bei Anforderung von ersatzteilen die dazu bestimmte karte bitte komplett ausfüllen.

FR LA COMMANDE DE PIÈCES DÉTACHÉES DOIT ÊTRE ACCOMPAGNÉE DES INDICATIONS SUIVANTES:

- 1) Modèle machine (ref. A)
- 2) Matricule (ref. B)
- 3) Année de construction (ref. C)
- 4) Numéro de la table
- 5) Numéro de référence du composant
- 6) Numéro de code du composant
- 7) Quantité requise
- 8) Mode d'expédition

Pour les composants colorés, spécifier le coloris.

NOTE:

Effectuer la demande de pièces de rechange en remplissant tous les points de la carte correspondante.

ES LOS PEDIDOS DE LAS PIEZAS DE REPUESTO DEBERÁN ESTAR ACOMPAÑADOS POR LAS INDICACIONES SIGUIENTES:

- 1) Modelo máquina (ref. A)
- 2) Matricula (ref. B)
- 3) Año de fabricación (ref. C)
- 4) Número de la tabla
- 5) Número de referencia de la pieza
- 6) Número de código de la pieza
- 7) Cantidad pedida
- 8) Modo de expedición

Especificar el color para los componentes de color.

NOTA:

Effectuar el pedido de los recambios completando la correspondiente ficha en todas sus partes.

		
MODELLO	<input type="text"/>	A
MATRICOLA	<input type="text"/>	B
DATA	<input type="text"/>	C
ALIMENTAZIONE	<input type="text"/>	V
FREQUENZA	<input type="text"/>	Hz
N. FASI	<input type="text"/>	
ASSORBIMENTO	<input type="text"/>	A
POTENZA TOT.	<input type="text"/>	kW
CONSUMO ARIA	<input type="text"/>	Nl/min
PRESSIONE MAX	<input type="text"/>	bar
PESO	<input type="text"/>	kg

TARGHETTA DI IDENTIFICAZIONE MACCHINA • MACHINE IDENTIFICATION
PLATE • TYPENSCHILD DER MASCHINE • PLAQUETTE D'IDENTIFICATION
DE LA MACHINE • PLAQUITA DE IDENTIFICACION MAQUINA

INDICE FIGURATIVO

PICTURE INDEX - ABBILDUNGSVERZEICHNIS
INDEX FIGURATIF - INDICE FIGURATIVO

IDM - 24153300900

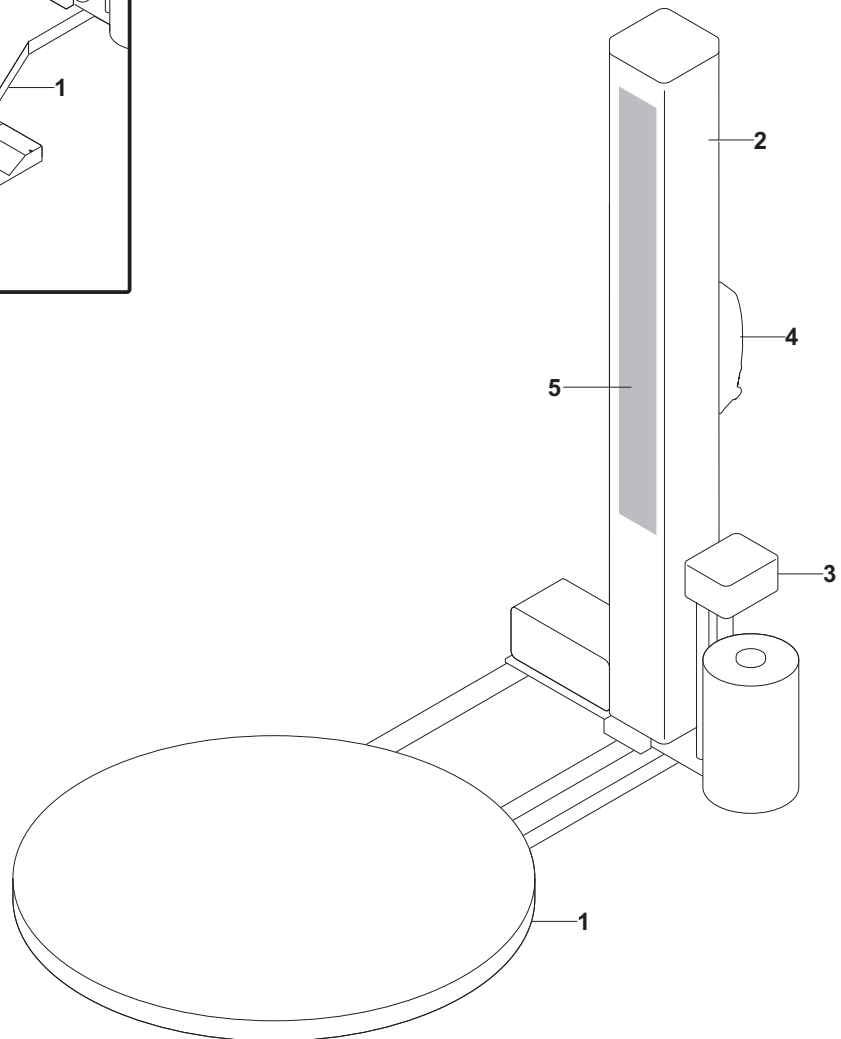
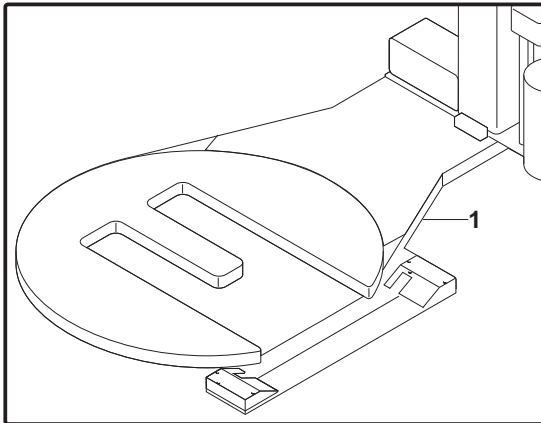

2415330

Rif.	Tav.	Tab.	Taf.	Descrizione • Description • Bezeichnung • Denomination • Denominazione
1	A	101/0		Basamento (Ø=1500mm) - (Portata massima=1200 kg) • Machine base (Ø=1500mm) - (Max. load =1200 kg) • Maschinenbett (Ø=1500mm) - (Ladefähigkeit max=1200 kg) • Machine bâti (Ø=1500mm) - (Capacité de charge maxi=1200 kg) • Base (Ø=1500mm) - (Capacidad máx=1200 kg)
1	A	102/0		Basamento (Ø=1500mm) - (Portata massima=2000 kg) • Machine base (Ø=1500mm) - (Max. load =2000 kg) • Maschinenbett (Ø=1500mm) - (Ladefähigkeit max=2000 kg) • Machine bâti (Ø=1500mm) - (Capacité de charge maxi=2000 kg) • Base (Ø=1500mm) - (Capacidad máx=2000 kg)
1	A	103/0		Basamento (Ø=1650mm) - (Portata massima=2000 kg) • Machine base (Ø=1650mm) - (Max. load =2000 kg) • Maschinenbett (Ø=1650mm) - (Ladefähigkeit max=2000 kg) • Machine bâti (Ø=1650mm) - (Capacité de charge maxi=2000 kg) • Base (Ø=1650mm) - (Capacidad máx=2000 kg)
1	A	104/0		Basamento "TP" (Ø=1500mm) • "TP" Machine base (Ø=1500mm) • Maschinenbett "TP" (Ø=1500mm) • Machine bâti "TP" (Ø=1500mm) • Base "TP" (Ø=1500mm)
1	A	105/0		Basamento "TP" (Ø=1650mm) • "TP" Machine base (Ø=1650mm) • Maschinenbett "TP" (Ø=1650mm) • Machine bâti "TP" (Ø=1650mm) • Base "TP" (Ø=1650mm)
2	B	101/0		Albero di scorrimento • Slide guide mast • Arbre de coulissement • Schubwelle • Árbol de deslizamiento
3	C	101/0		Carrello portabobina "FRD" • Reel holding carriage "FRD" • Spulenhaltewage "FRD" • Chariot porte-bobine "FRD" • Carro portabobina "FRD"
3	C	102/0		Carrello portabobina "FRD" per rete • "FRD" reel carriage for mesh • Rollenständer "FRD" für verpackungsnetz • Chariot porte-bobine "FRD" pour filet • Carro portabobina "FRD" para red
3	C	103/0		Carrello portabobina "RS" • Reel holding carriage "RS" • Spulenhaltewage "RS" • Chariot porte-bobine "RS" • Carro portabobina "RS"
3	C	104/0		Carrello portabobina "PPS" • Reel holding carriage "PPS" • Spulenhaltewage "PPS" • Chariot porte-bobine "PPS" • Carro portabobina "PPS"
3	C	105/0		Motorizzazione carrello "PPS" • Carriage motorization "PPS" • Wagenmotorisierung "PPS" • Motorisation du chariot "PPS" • Motorización carro "PPS"
4	D	101/0		Quadro elettrico • Electric cabinet • Elektrische Schalttafel • Tableau électrique • Cuadro eléctrico
5	E	101/0		Gruppo targhe • Plates unit • Plakettengruppe • Groupe plaques • Grupo placas

BASAMENTO (Ø=1500mm) - (Portata massima=1200 kg)**A 101** 00

MACHINE BASE (Ø=1500mm) - (Max. load =1200 kg) - MASCHINENBETT (Ø=1500mm) - (Ladefähigkeit max=1200 kg)

MACHINE BÂTI (Ø=1500mm) - (Capacité de charge maxi=1200 kg) - BASE (Ø=1500mm) - (Capacidad máx=1200 kg)

IDM - 24153300100

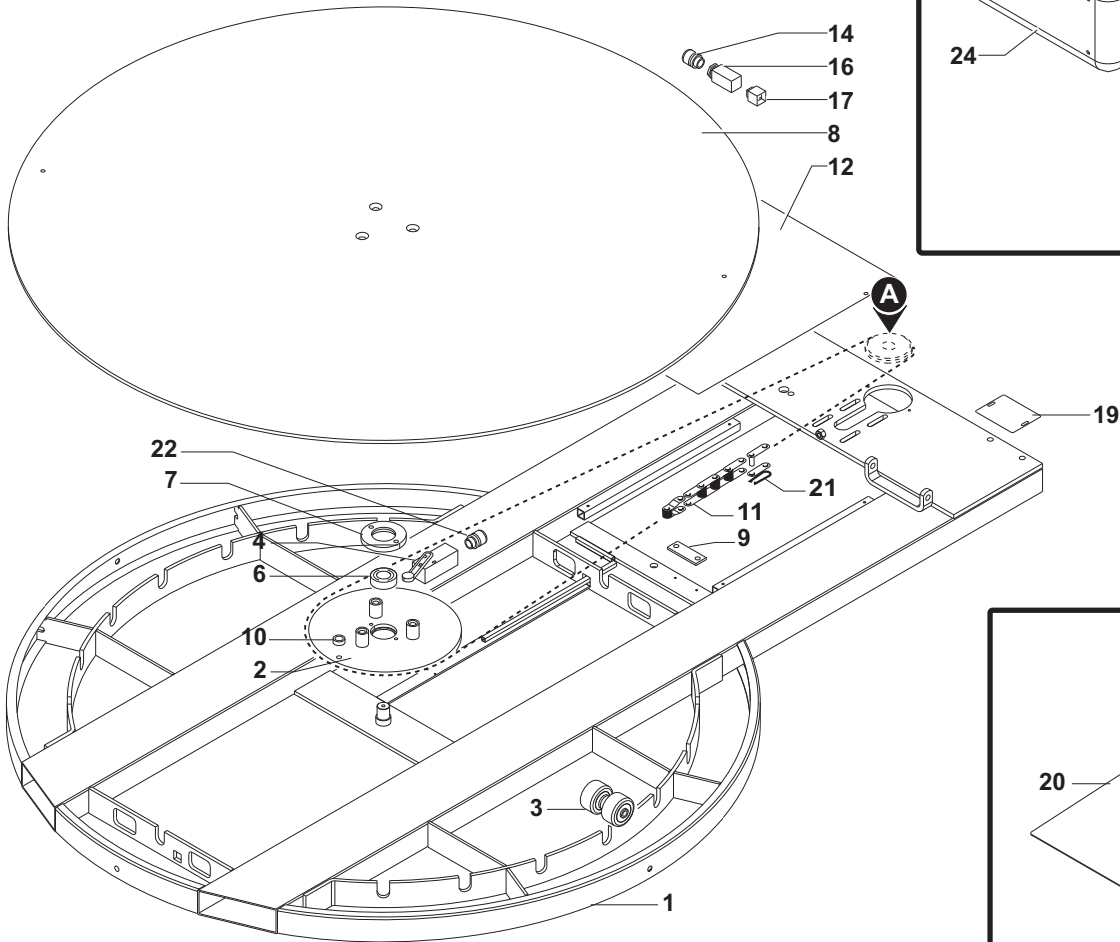

2415330

N. Cod.

1 3920300283
 2 4400300000
 3 2544300028
 4 0001309639
 5 3740300371
 6 0000606110
 7 4730300005
 8 5340300300
 9 0380602003
 10 0380150094
 11 0000606790
 12 4940300677
 13 0000645066

N. Cod.

14 0001304627
 15 0001330129
 16 0001357351
 17 0001353017
 18 2750300002
 19 4250301007
 20 5710300042
 21 0000602096
 22 0001304210
 23 4250300305
 24 5210300277

N. Cod.**N. Cod.**

BASAMENTO (Ø=1500mm) - (Portata massima=2000 kg)**A 102** 00

MACHINE BASE (Ø=1500mm) - (Max. load =2000 kg) - MASCHINENBETT (Ø=1500mm) - (Ladefähigkeit max=2000 kg)

MACHINE BÂTI (Ø=1500mm) - (Capacité de charge maxi=2000 kg) - BASE (Ø=1500mm) - (Capacidad máx=2000 kg)

IDM - 24153300200

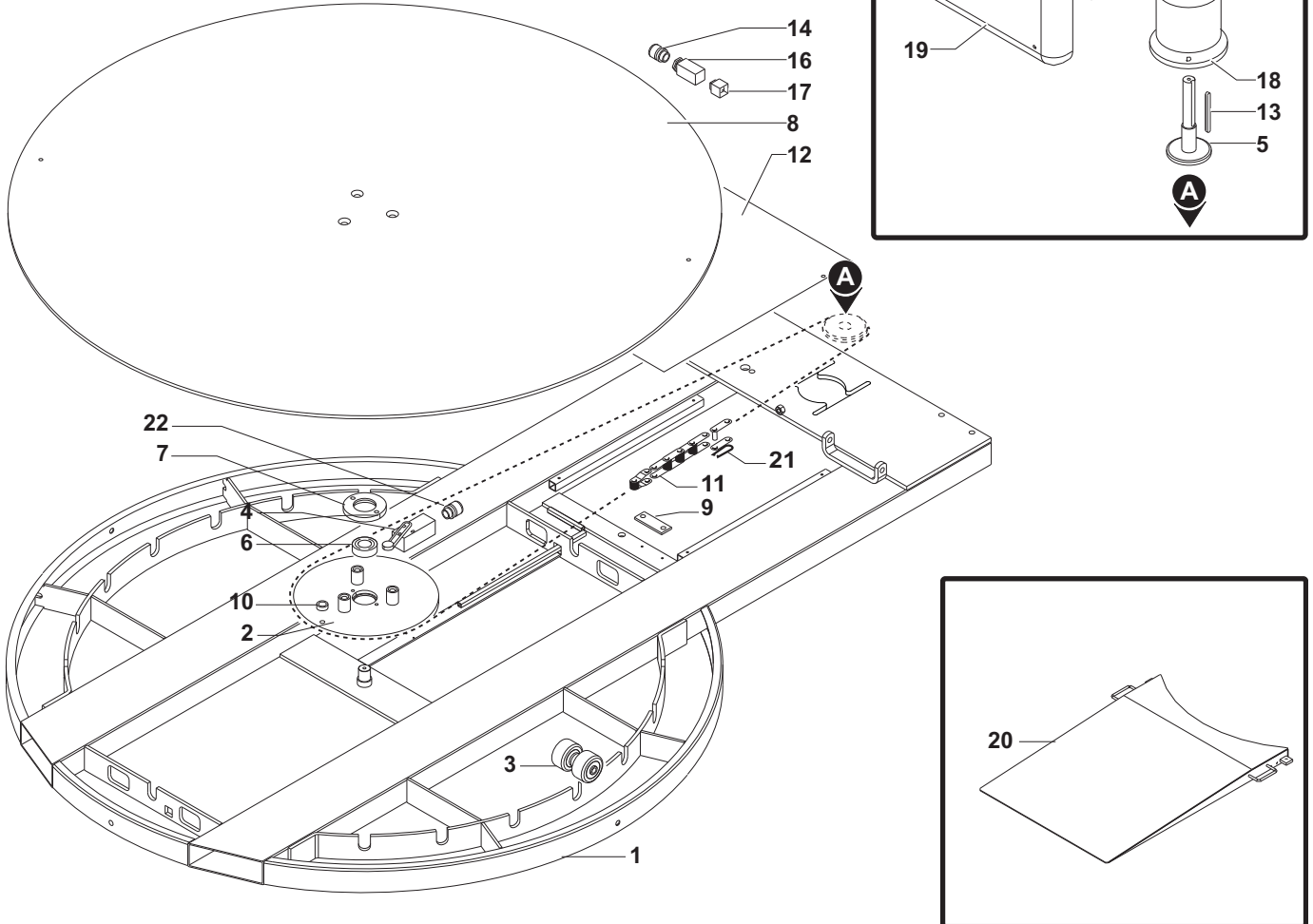

2415330

N. Cod.

1 3920300226
 2 4400300000
 3 2544300028
 4 0001309639
 5 3740300313
 6 0000606110
 7 4730300005
 8 5340300283
 9 0380602003
 10 0380150094
 11 0000605998
 12 4940300677
 13 0000645200

N. Cod.

14 0001304627
 15 0001339103
 16 0001357351
 17 0001353017
 18 0000640722
 19 5210300277
 20 5710300042
 21 0000602096
 22 0001304210
 23 4250300305

N. Cod.**N. Cod.**

BASAMENTO (Ø=1650mm) - (Portata massima=2000 kg)**A 103** 00

MACHINE BASE (Ø=1650mm) - (Max. load =2000 kg) - MASCHINENBETT (Ø=1650mm) - (Ladefähigkeit max=2000 kg)

MACHINE BÂTI (Ø=1650mm) - (Capacité de charge maxi=2000 kg) - BASE (Ø=1650mm) - (Capacidad máx=2000 kg)

IDM - 24153300300

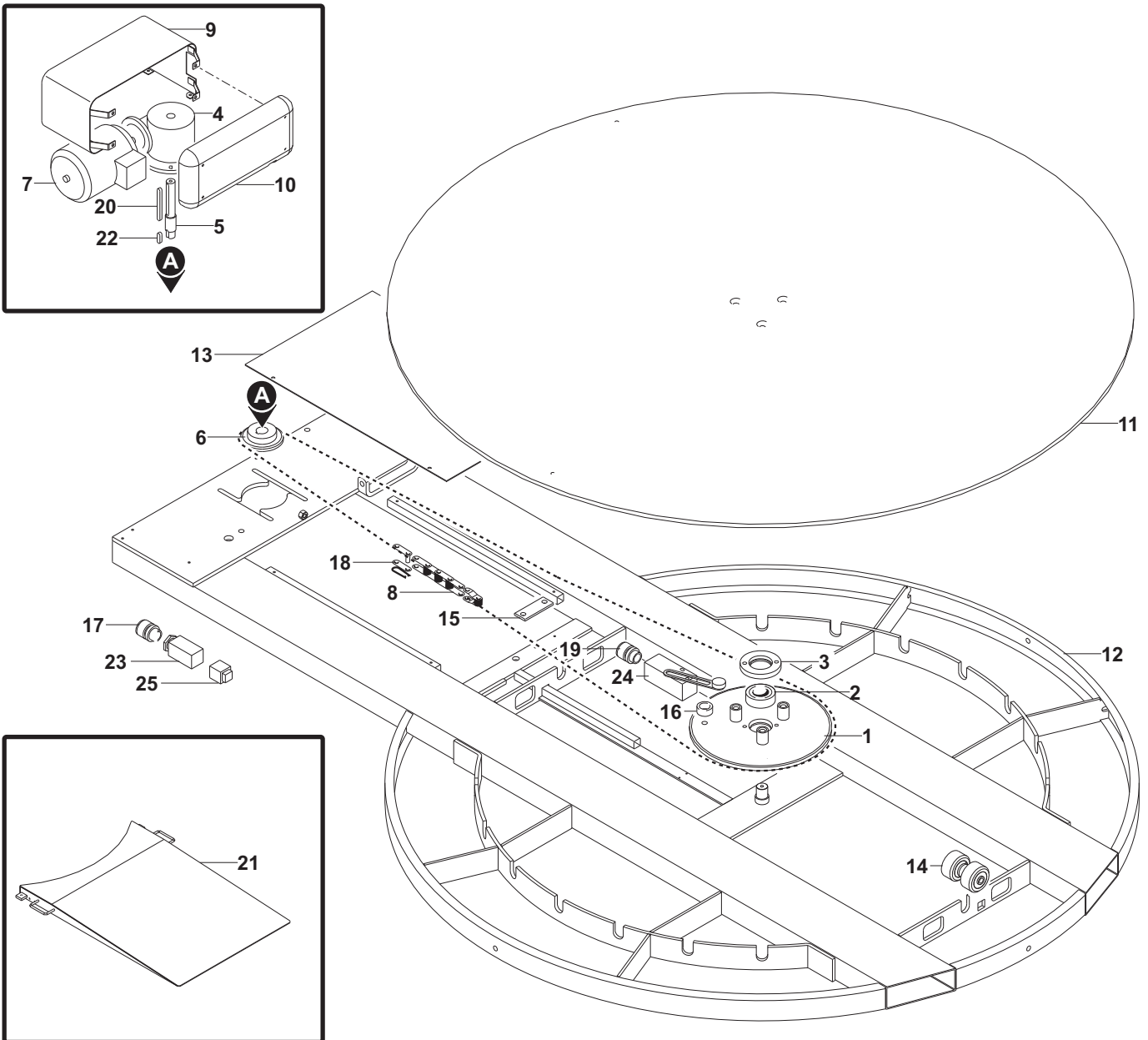

2415330

N. Cod.

1 4400300000
 2 0000606110
 3 4730300005
 4 0000640722
 5 3740300318
 6 0380610413
 7 0001322316
 8 0000605999
 9 4250300305
 10 5210300277
 11 5340300075
 12 3920300227
 13 4940300186

N. Cod.

14 2544300028
 15 0380602003
 16 0380150094
 17 0001304627
 18 0000602096
 19 0001304210
 20 0000645101
 21 5710300027
 22 0000645033
 23 0001357351
 24 0001309639
 25 0001353017

N. Cod.**N. Cod.**

BASAMENTO "TP" (Ø=1500mm)

"TP" MACHINE BASE (Ø=1500mm) - MASCHINENBETT "TP" (Ø=1500mm)
 MACHINE BÂTI "TP" (Ø=1500mm) - BASE "TP" (Ø=1500mm)

IDM - 24153300400

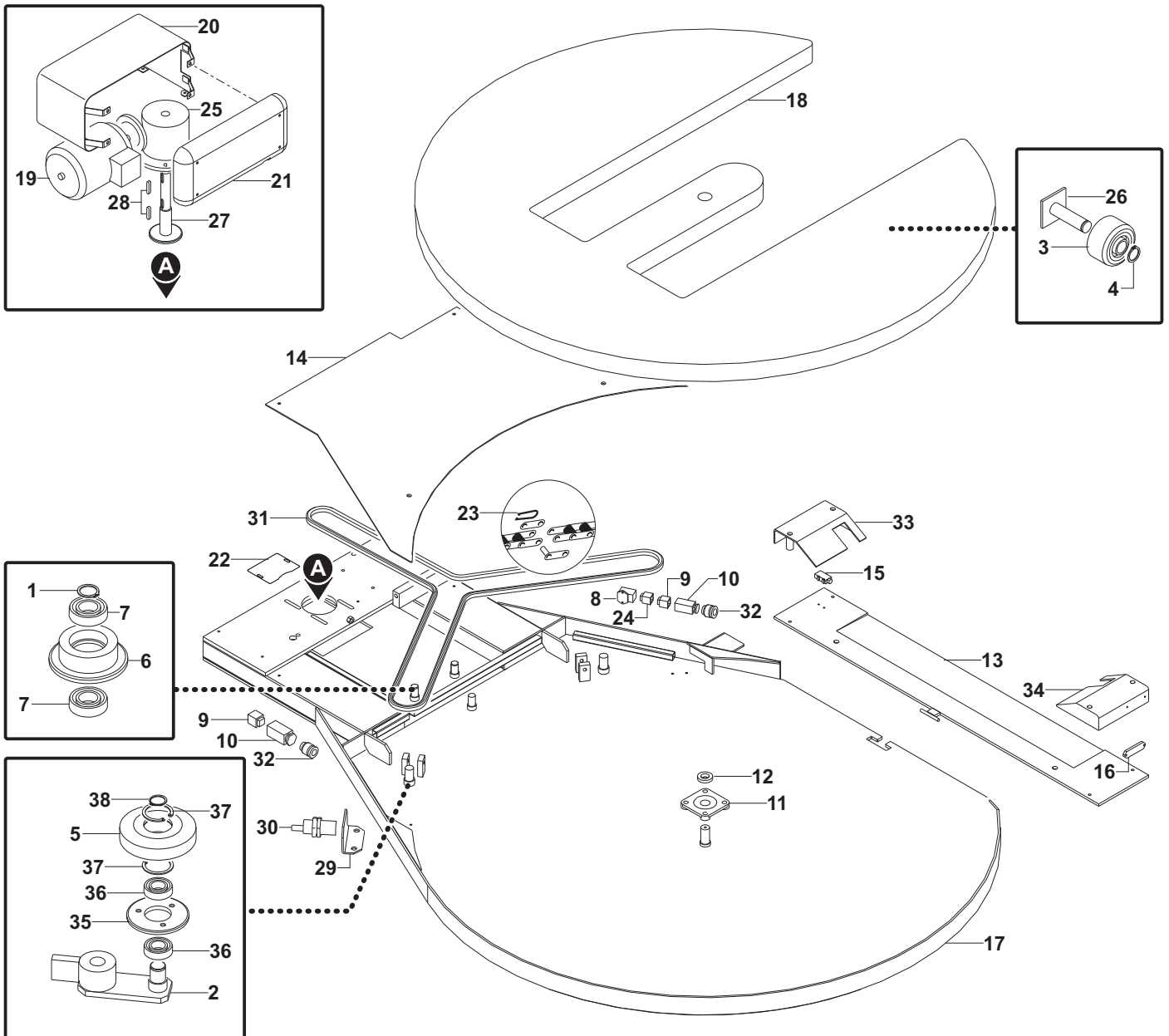

2415330

N. Cod.	N. Cod.	N. Cod.	N. Cod.
1 0000644268	14 4940300967	27 3740300483	
2 0580794820	15 0001300331	28 0000645033	
3 2544300004	16 0001300332	29 0380794510	
4 0000644263	17 3920300282	30 0001300301	
5 0380710300	18 5340300305	31 0000609804	
6 0380610170	19 0001339103	32 0001304627	
7 0000606100	20 4250300305	33 4250300304	
8 0001357136	21 5210300277	34 4250300303	
9 0001353017	22 4250301007	35 0380730580	
10 0001357351	23 0000602875	36 0000606101	
11 0000613228	24 0001353016	37 0000644048	
12 0000305253	25 2750300003	38 0000644273	
13 4940300184	26 0580581810		

BASAMENTO "TP" (Ø=1650mm)

A 105 00

"TP" MACHINE BASE (Ø=1650mm) - MASCHINENBETT "TP" (Ø=1650mm)
 MACHINE BÂTI "TP" (Ø=1650mm) - BASE "TP" (Ø=1650mm)

IDM - 24153300500

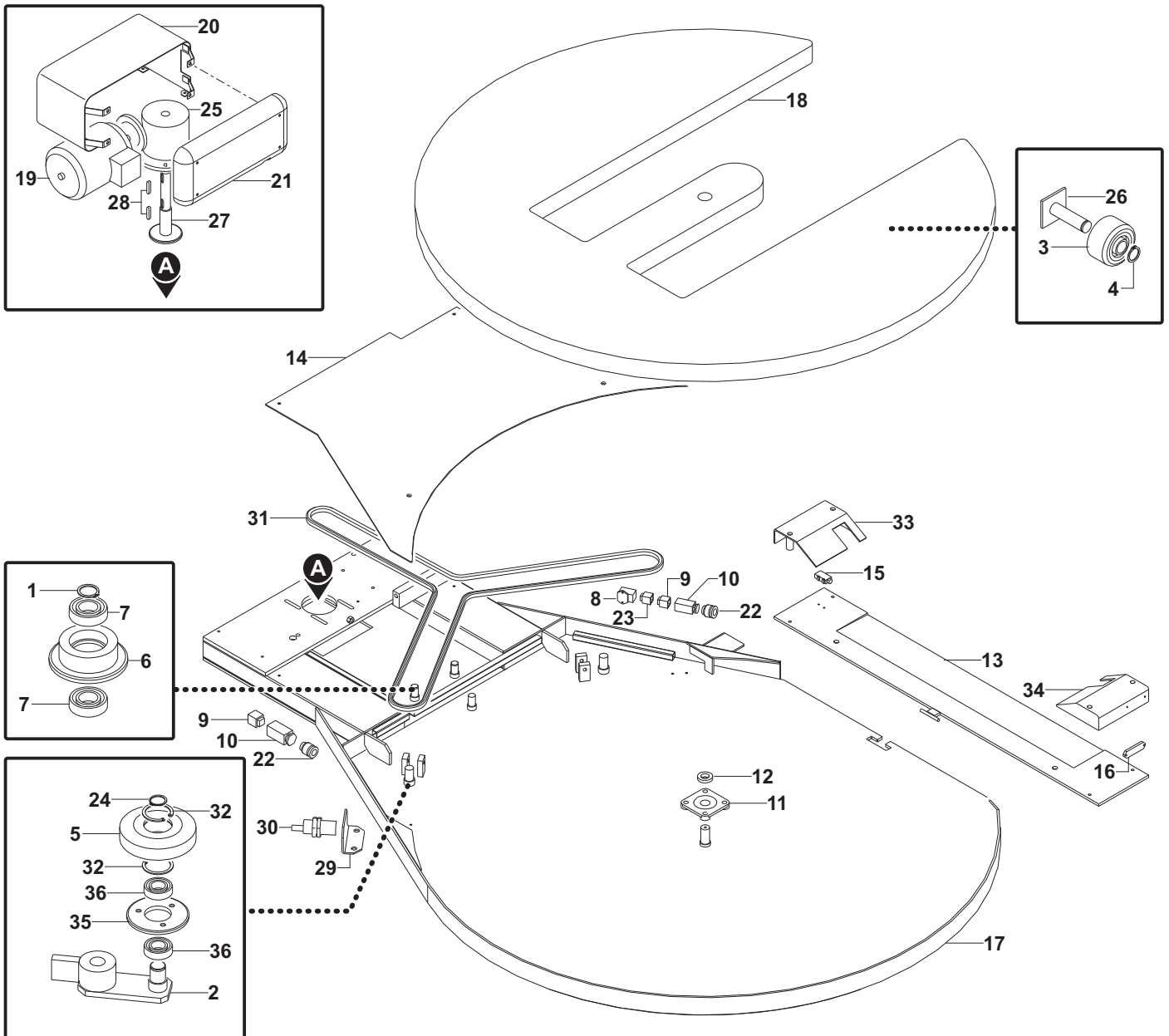

2415330

N. Cod.	N. Cod.	N. Cod.	N. Cod.
1 0000644268	14 4940300185	27 3740300320	
2 0580794820	15 0001300331	28 0000645033	
3 2544300004	16 0001300332	29 0380794510	
4 0000644263	17 3920300251	30 0001300301	
5 0380710300	18 5340300077	31 0000600335	
6 0380610170	19 0001322316	32 0000644048	
7 0000606100	20 4250300305	33 4250300304	
8 0001357136	21 5210300277	34 4250300303	
9 0001353017	22 0001304627	35 0380730580	
10 0001357351	23 0001353016	36 0000606101	
11 0000613228	24 0000644273		
12 0000305253	25 0000640749		
13 4940300184	26 0580581810		

ALBERO DI SCORRIMENTO

SLIDE GUIDE MAST - SCHUBWELLE

ARBRE DE COULISSEMENT - ÁRBOL DE DESLIZAMIENTO

IDM - 24153300600

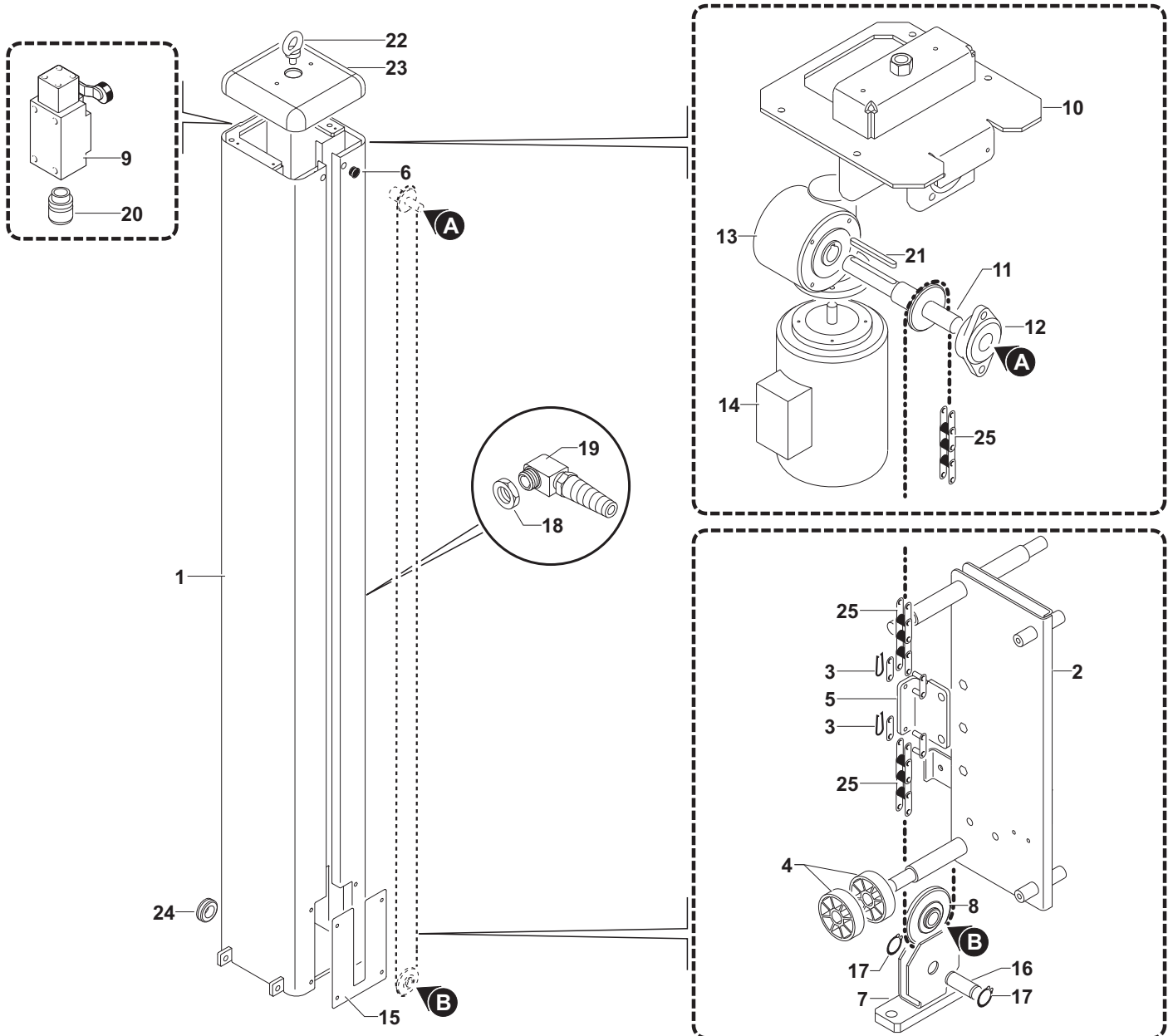

2415330

N. Cod.		N. Cod.		N. Cod.		N. Cod.		
H=2200	1 4820300556	12	0000613239	FRD-RS	21	0000645018		
H=2400	1 4820300565	FRD-RS	13	2751300010	net "FRD"-PPS	21	0000645110	
	2 6040300349	net "FRD"-PPS	13	0000640972		22	0000630143	
	3 0000602875	FRD-RS	14	2212300005		23	4350300064	
	4 2544300000	net "FRD"-PPS	14	0001339714		24	0001349528	
	5 5830300418		15	4940300960		H=2200	25	2480300005
	6 0000640028		16	0381581750		H=2400	25	2480300006
	7 6160300027		17	0000644264				
	8 0000618160	FRD-RS	18	0001301278				
	9 0001309639	PPS	18	0001350583				
	10 5890301344	FRD-RS	19	0890300001				
	FRD-RS	11	3740300481	PPS	19	0890300003		
	net "FRD"-PPS	11	3740300138	20	0001304210			

CARRELLO PORTABOBINA "FRD"

REEL HOLDING CARRIAGE "FRD" - SPULENHALTEWAGE "FRD"
 CHARIOT PORTE-BOBINE "FRD" - CARRO PORTABOBINA "FRD"

IDM - 24153300800

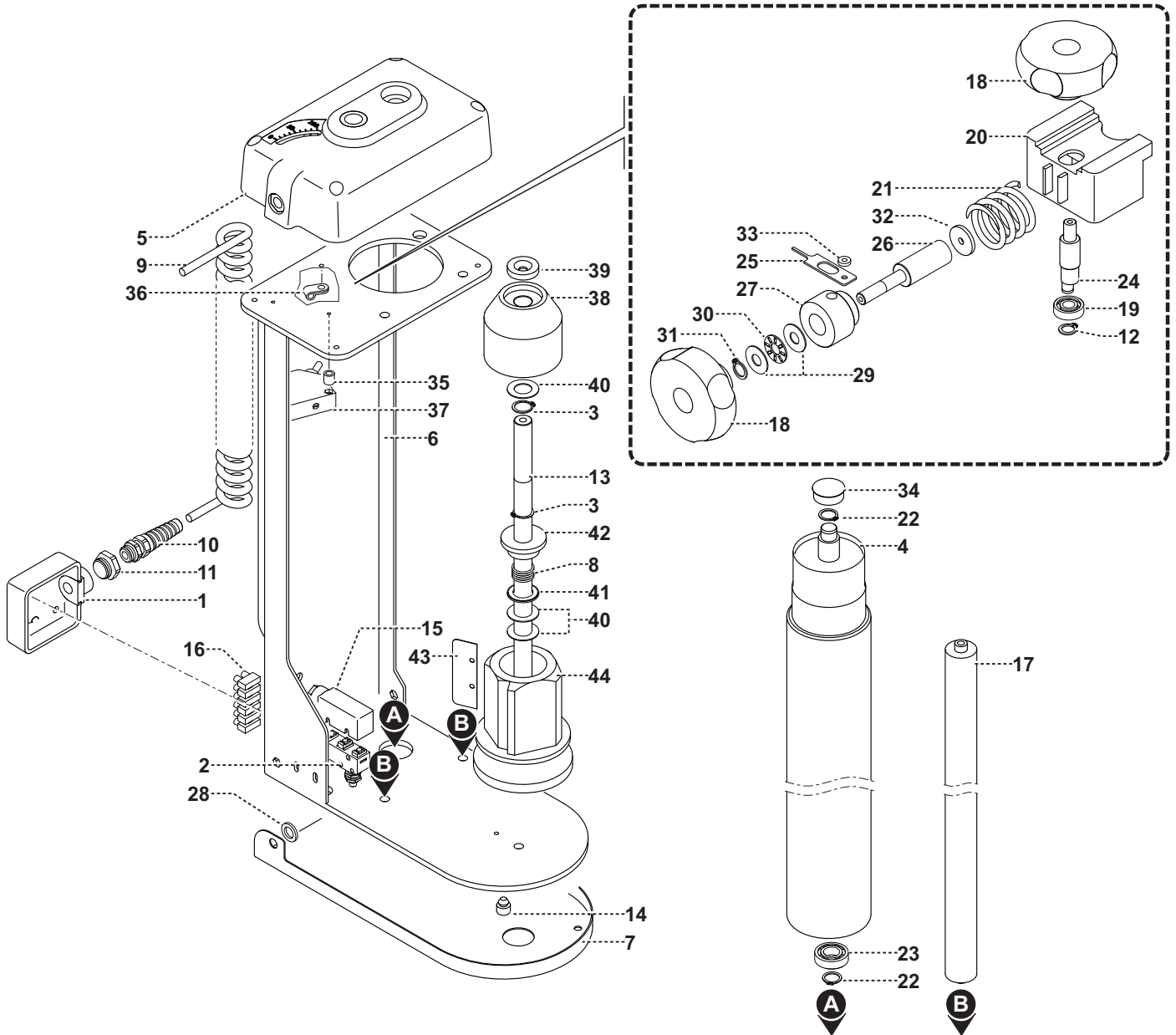

2415330

N. Cod.	N. Cod.	N. Cod.	N. Cod.
1 4350300094	14 0000636640	27 5090300006	40 0000613044
2 0001310459	15 0001347611	28 0000305216	41 0000613040
3 0000644265	16 0001351790	29 0000613073	42 0380150671
4 5650300249	17 0000641633	30 0000613092	43 0380530554
5 4250300987	18 0000619709	31 0000644258	44 0380540074
6 6040300466	19 0000606233	32 0000305946	
7 4250301080	20 3980300000	33 0000626963	
8 0380530192	21 5121300041	34 0000640023	
9 0742300001	22 0000644263	35 0000626764	
10 0001304628	23 0000606040	36 0001506009	
11 0001908339	24 5270300589	37 0001310154	
12 0000644257	25 5000300051	38 0380150651	
13 3740300000	26 2992300066	39 0000305253	

CARRELLO PORTABOBINA "FRD" PER RETE

"FRD" REEL CARRIAGE FOR MESH - ROLLENSTÄNDER "FRD" FÜR VERPACKUNGSNETZ
 CHARIOT PORTE-BOBINE "FRD" POUR FILET - CARRO PORTABOBINA "FRD" PARA RED

IDM - 24153300700

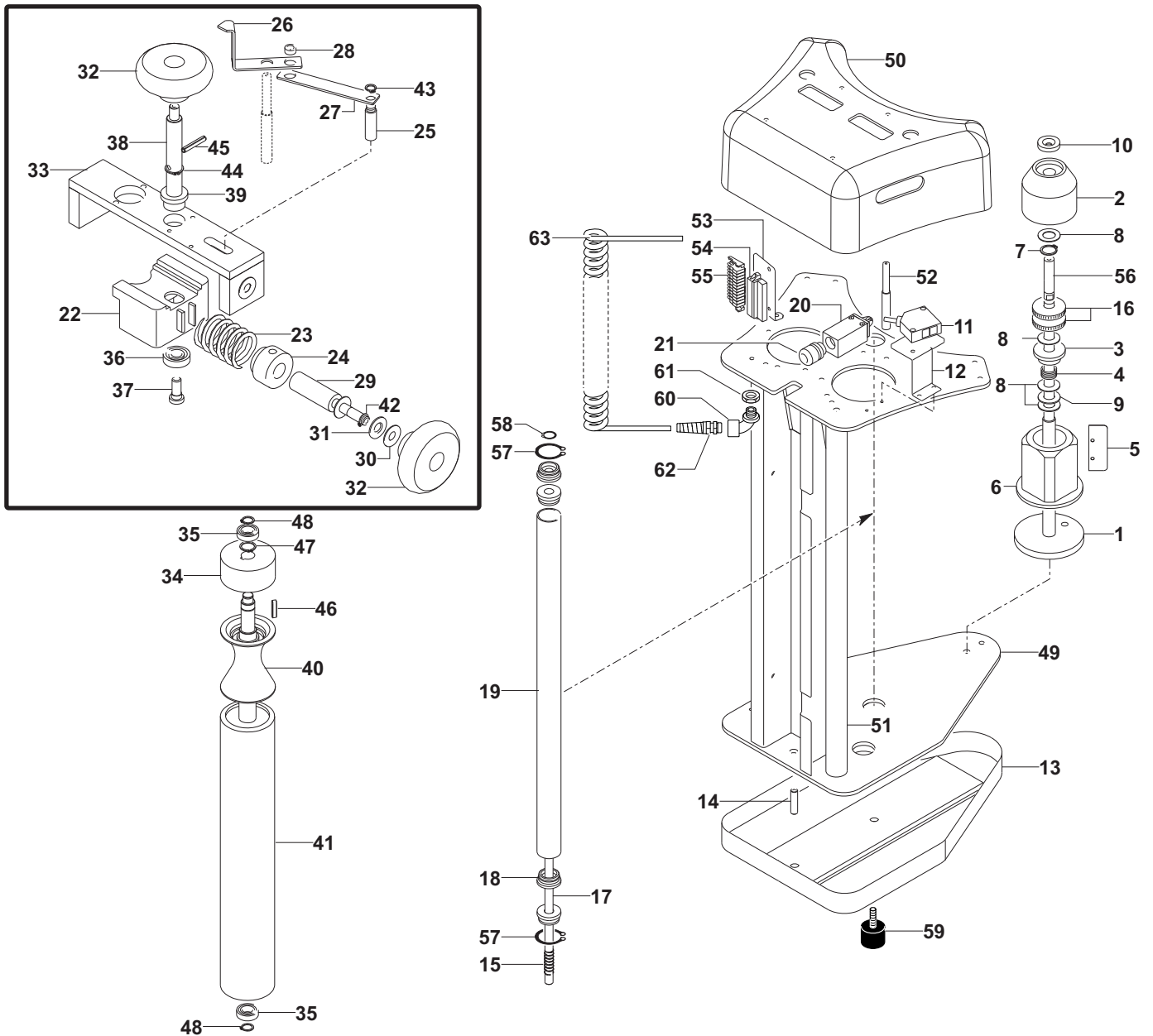

2415330

N. Cod.	N. Cod.	N. Cod.	N. Cod.
1 5270300498	20 0001309611	39 0000601049	58 0000644260
2 0380150651	21 0001304210	40 4040300007	59 0000624121
3 0000601114	22 3980300000	41 5650300134	60 0000625911
4 0380530115	23 0380530383	42 0000644258	61 0001301278
5 0380530554	24 5090300000	43 0000644256	62 0001304628
6 0380540074	25 5270300057	44 0000644264	63 0742300001
7 0000644265	26 4940300127	45 0000306236	
8 0000613044	27 5000300043	46 0000645059	
9 0000613040	28 0380150561	47 0000644268	
10 0000305253	29 2992300000	48 0000644263	
11 0001310154	30 0000613073	49 6040300474	
12 5830300277	31 0000613092	50 4250300900	
13 4250300901	32 0000619709	51 0000641013	
14 5270300071	33 5330300002	52 5270300540	
15 0380530171	34 5400300003	53 5790300060	
16 0000610082	35 0000606040	54 0001351528	
17 5270300094	36 0000606233	55 0001351419	
18 4040300004	37 2963300000	56 5270300499	
19 2300300011	38 5270300005	57 0000644278	

CARRELLO PORTABOBINA "RS"

REEL HOLDING CARRIAGE "RS" - SPULLENHALTEWAGE "RS"
 CHARIOT PORTE-BOBINE "RS" - CARRO PORTABOBINA "RS"

IDM - 24153301300

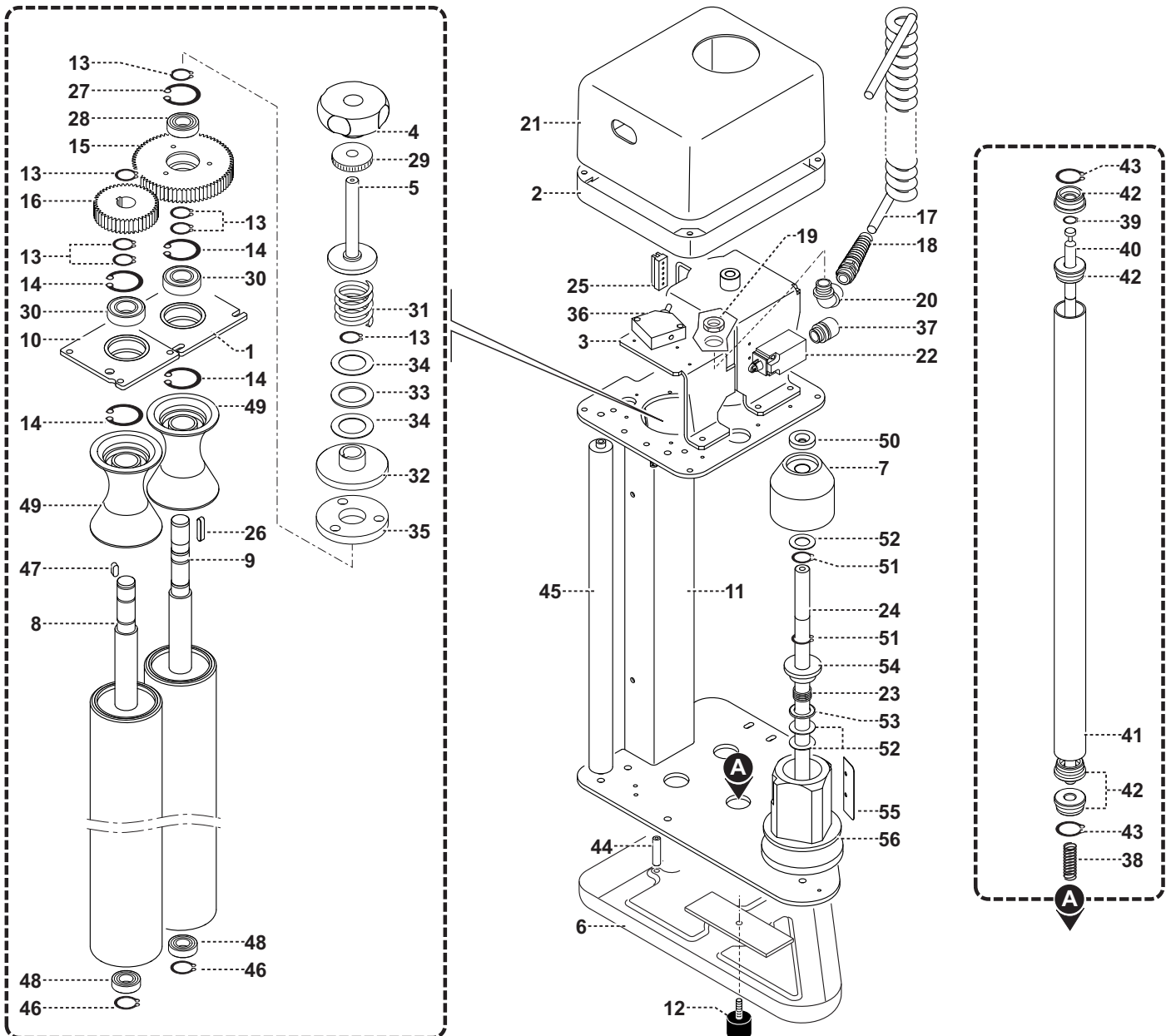

2415330

N. Cod.	N. Cod.	N. Cod.	N. Cod.
1 5330300538	90% 16 2540300133	35 4520300064	54 0380150671
2 4250301087	17 0742300001	36 0001310154	55 0380530554
3 5830300446	18 0001304628	37 0001304210	56 0380540074
4 0000619600	19 0001301278	38 0380530171	
5 4130300016	20 0000625911	39 0000644260	
6 4250300363	21 4250301088	40 5270300014	
7 0380150651	22 0001309611	41 2300300011	
8 5650300133	23 0380530192	42 4040300004	
9 5650300316	24 3740300000	43 0000644278	
10 5330300402	25 0001351790	44 5270300071	
11 6040300476	26 0000645059	45 0000641013	
12 0000624121	27 0000644038	46 0000644263	
13 0000644268	28 0000606439	47 0000645040	
14 0000644043	29 0000610082	48 0000606040	
30% 15 2540300130	30 0000606100	49 4040300007	
60% 15 2540300129	31 0380530383	50 0000305253	
90% 15 2540300128	32 4520300065	51 0000644265	
30% 16 2540300131	33 0000613033	52 0000613044	
60% 16 2540300132	34 0000613034	53 0000613040	

CARRELLO PORTABOBINA "PPS"

REEL HOLDING CARRIAGE "PPS" - SPULENHALTEWAGE "PPS"
 CHARIOT PORTE-BOBINE "PPS" - CARRO PORTABOBINA "PPS"

IDM - 24153301000

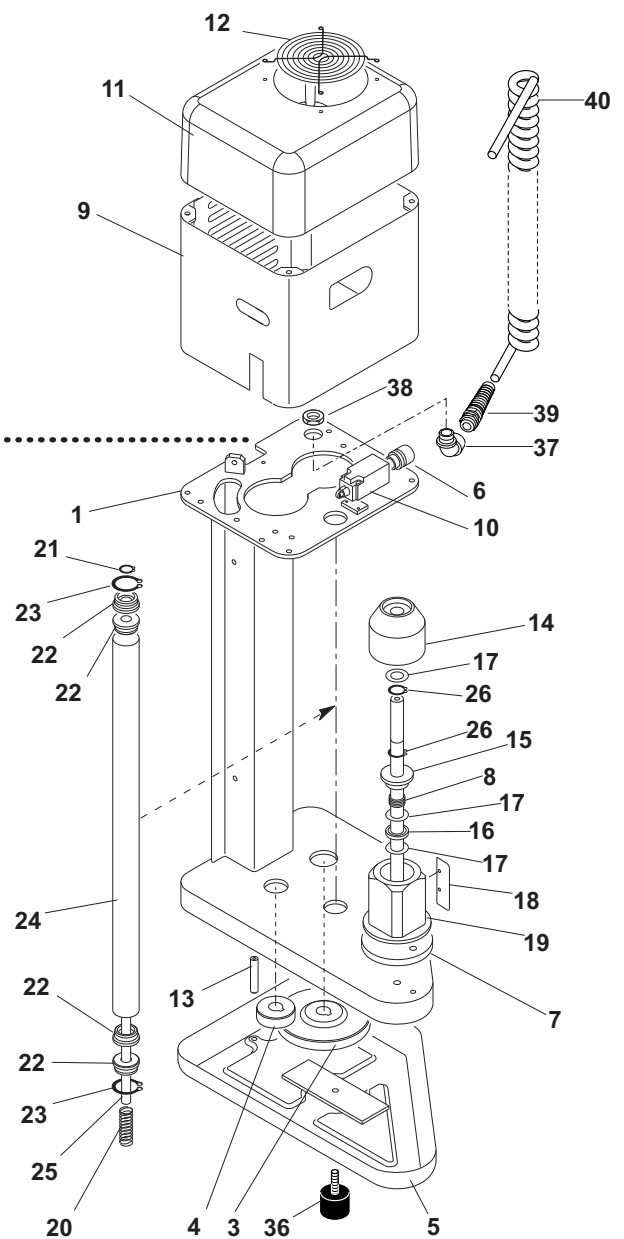
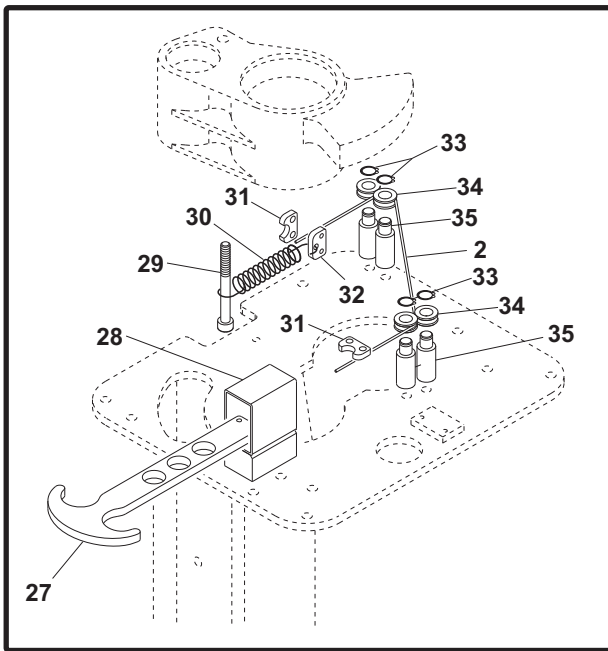

2415330

N. Cod.

	1	6040300475
	2	4640300000
PPS 150%	3	2540300091
PPS 200%	3	2540300093
PPS 250%	3	2540300087
PPS 150%	4	2540300092
PPS 200%	4	2540300094
PPS 250%	4	2540300088
	5	4250300363
	6	0001304210
	7	3740300000
	8	0380530192
	9	4250300970

N. Cod.

	10	0001309611
	11	4250300928
	12	0000639002
	13	5270300482
	14	0380150651
	15	0380150671
	16	0000613040
	17	0000613044
	18	0380530554
	19	0380540074
	20	0380530171
	21	0000644260
	22	4040300004

N. Cod.

	23	0000644278
	24	2300300072
	25	5270300578
	26	0000644265
	27	5000300050
	28	5890301049
	29	0000309190
F=107N	30	5120300029
F=214N	30	5120300030
F=321N	30	5120300031
	31	5150300007
	32	5330300450
	33	0000644256

N. Cod.

	34	4820300462
	35	5270300568
	36	0000624121
	37	0000629495
	38	0001350583
	39	0890300002
	40	0742300002

MOTORIZZAZIONE CARRELLO "PPS"

CARRIAGE MOTORIZATION "PPS" - WAGENMOTORISIERUNG "PPS"
 MOTORISATION DU CHARIOT "PPS" - MOTORIZACIÓN CARRO "PPS"

IDM - 24153301100

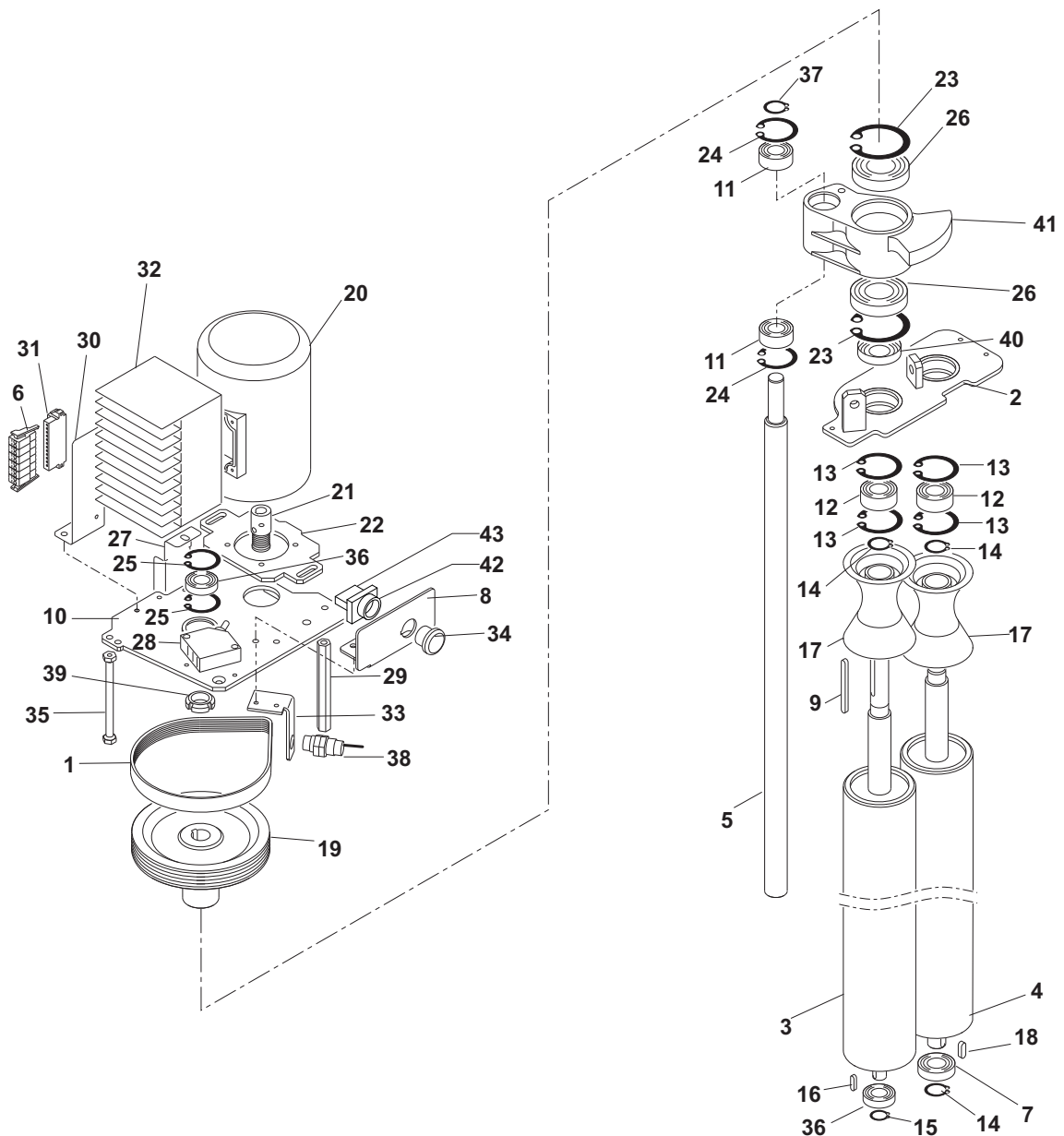

2415330

N. Cod.	N. Cod.	N. Cod.	N. Cod.
1 0000604812	14 0000644268	27 4250300969	40 5590300023
2 5330300462	15 0000644263	28 0001310154	41 3950300054
3 5650300230	16 0000645063	29 4550300202	42 0001300700
4 5650300219	17 4040300007	30 5790300025	43 0001300024
5 5651300223	18 0000645184	31 0001351537	
6 0001351538	19 5400300076	32 1430300114	
7 0000606439	20 2212300005	33 5830300286	
8 5890301067	21 5400300077	34 0001300762	
9 0000645018	22 5330300453	35 4550300213	
10 5330300452	23 0000644062	36 0000606040	
11 0000606045	24 0000644036	37 0000644265	
12 0000606100	25 0000644033	38 0001309314	
13 0000644043	26 0000606446	39 0000301849	

QUADRO ELETTRICOSWITCHBOARD - SCHALTSCHRANK
TABLEAU ÉLECTRIQUE - TABLERO ELÉCTRICO

IDM - 24153301200

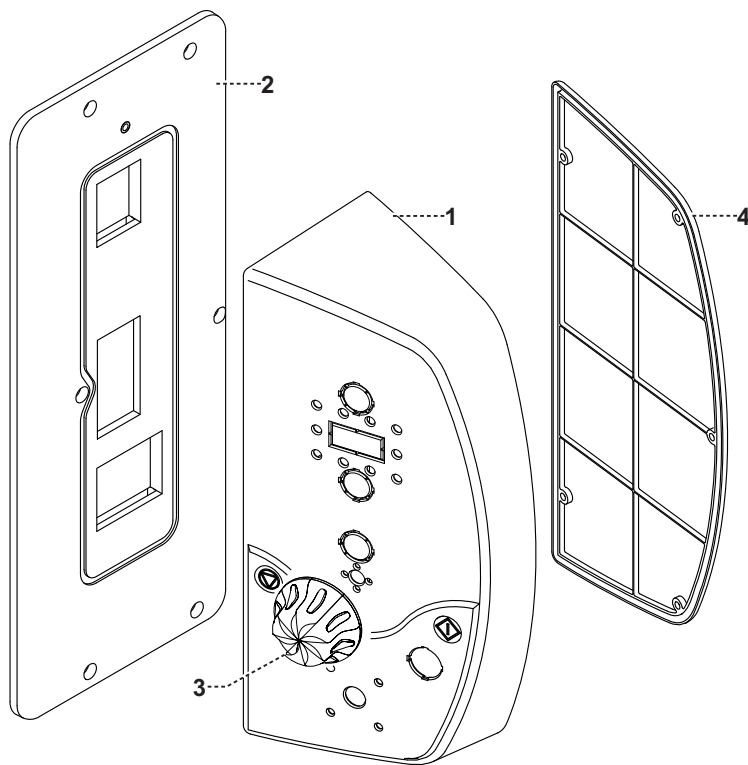

* Modello macchina (Serie Ecoplat)
 Machine type (Ecoplat Series)
 * Maschinenmodell (Serie Ecoplat)
 Modèle machine (Série Ecoplat)
 Modelo máquina (Serie Ecoplat)

2415330

N. Cod.	N. Cod.	N. Cod.	N. Cod.
1 4280300133			
2 5330300533			
* 3 6220300017			
4 4350300092			

